

RAA788150, RAA788152, RAA788153, RAA788155, RAA788156, RAA788158

Large 3V Output Swing, 5kV EFT, 16.5kV ESD, RS-485 Transceivers

The RAA78815x family (RAA788150, RAA788152, RAA788153, RAA788155, RAA788156, RAA788158) of 5V powered RS-485 transceivers features high output drive and high EFT and ESD protection.

The devices are immune to ±5kV IEC61000-4-4 EFT transients and withstand ±16.5kV IEC61000-4-2 ESD strikes without latch-up.

The large output voltage of 3.1V typical into a 54Ω load provides high noise immunity, and it enables the drive of up to 8000ft long bus segments or eight 120Ω terminations in a star topology.

These devices possess less than 125μA bus input currents, therefore, constituting a true 1/8 unit load. The high output drive combined with the low bus input currents allows for the connection of up to 512 transceivers on the same bus.

The receiver inputs feature a full fail-safe design that turns the receiver outputs high when the bus inputs are open or shorted.

The RAA78815x family includes half and full-duplex transceivers with active-high driver-enable pins and active-low receiver enable pins. These transceivers support data rates of 115kbps, 1Mbps, and 20Mbps with a performance that is characterized from -40°C to +85°C.

Features

- High V<sub>OD</sub>: 3.1V (Typ) into R<sub>D</sub> = 54Ω
- ±5kV EFT immunity of bus I/O pins
- ±16.5kV ESD protection on bus I/O pins
- Supported data rates: 115kbps, 1Mbps, 20Mbps
- Full fail-safe outputs for open or shorted inputs
- Hot plug capability
- 1/8 Unit Load
- Allows for up to 512 transceivers on the bus
- Low supply current (driver disabled): 550μA
- Ultra-low shutdown current: 70nA

Applications

- Industrial networks in factory automation
- Building automation: lighting, elevators, HVAC
- Industrial process control networks
- Security camera networks
- Networks with star topology
- Long-haul networks in coal mines and oil rigs
- High node-count networks
- Automated utility e-meter reading systems

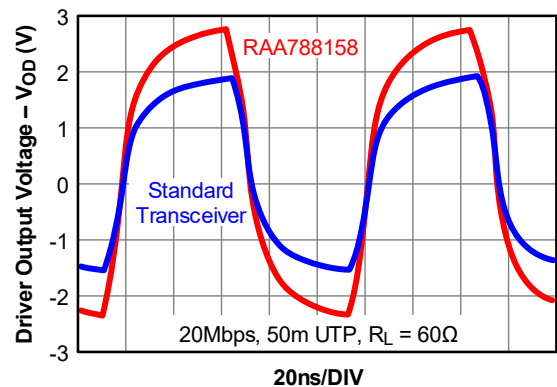
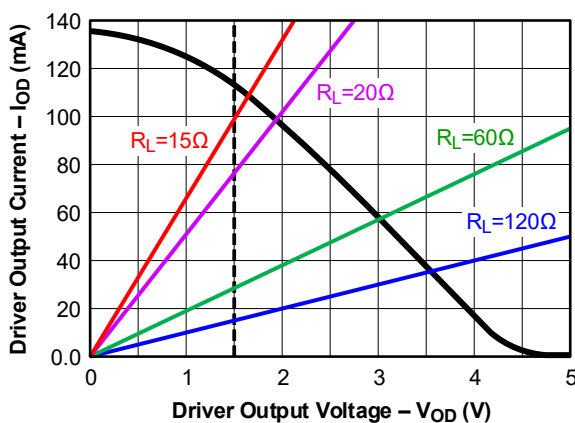

Figure 1. Typical Driver Output Performance of RAA78815xE Transceivers

## Contents

<b>1. Overview</b>	<b>3</b>
1.1 Typical Operating Circuit	3
<b>2. Pin Information</b>	<b>3</b>
2.1 Pin Assignments	3
2.2 Pin Descriptions	4
<b>3. Specifications</b>	<b>5</b>
3.1 Absolute Maximum Ratings	5
3.2 Recommended Operating Conditions	5
3.3 Thermal Information	5
3.4 Electrical Specifications	6
<b>4. Test Circuits and Waveforms</b>	<b>11</b>
<b>5. Typical Performance Curves</b>	<b>14</b>
<b>6. Device Description</b>	<b>16</b>
6.1 Overview	16
6.2 Functional Block Diagram	16
6.3 Operating Modes	16
6.4 Device Features	17
<b>7. Application Information</b>	<b>21</b>
7.1 Network Design	21
7.2 Transient Protection	26
7.3 Layout Guidelines	27
<b>8. Package Outline Drawings</b>	<b>28</b>
<b>9. Ordering Information</b>	<b>32</b>
<b>10. Revision History</b>	<b>33</b>

# 1. Overview

## 1.1 Typical Operating Circuit

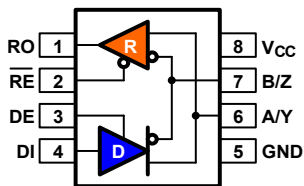

Figure 2. Typical Operating Circuits of Half-Duplex and Full-Duplex Transceivers

# 2. Pin Information

## 2.1 Pin Assignments

RAA788152, RAA788155, RAA788158  
(8 Ld MSOP, 8 Ld SOIC)  
Top View



RAA788150, RAA788153, RAA788156  
(10 Ld MSOP)  
Top View



RAA788150, RAA788153, RAA788156  
(14 Ld SOIC)  
Top View

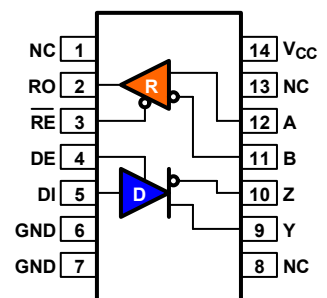

## 2.2 Pin Descriptions

8 Ld SOIC	10 Ld MSOP	14 Ld SOIC	Pin Name	Function
1	1	2	RO	Receiver output: If A-B $\geq$ -50mV, RO is high; If A-B $\leq$ -200mV, RO is low. RO is fail-safe High if A and B are unconnected (open) or shorted.
2	2	3	RE	Receiver output enable. RO is enabled when $\overline{\text{RE}}$ is low; RO is high impedance when $\overline{\text{RE}}$ is high.
3	3	4	DE	Driver output enable. The driver outputs, Y and Z, are enabled by bringing DE high. They are high impedance when DE is low.
4	4	5	DI	Driver input. A low on DI forces output Y low and output Z high. Similarly, a high on DI forces output Y high and output Z low.
5	5	6, 7	GND	Ground connection.
6	–	–	A/Y	Non-inverting receiver input and non-inverting driver output. Pin is an input if DE = 0; pin is an output if DE = 1.
7	–	–	B/Z	Inverting receiver input and inverting driver output. Pin is an input if DE = 0; pin is an output if DE = 1.
–	6	9	Y	Non-inverting driver output.
–	7	10	Z	Inverting driver output.
–	8	11	B	Inverting receiver input.
–	9	12	A	Non-inverting receiver input.
8	10	–	VCC	System power supply input (4.5V to 5.5V).
–	–	1, 8, 13	NC	No connection.

### 3. Specifications

#### 3.1 Absolute Maximum Ratings

**CAUTION:** Do not operate at or near the maximum ratings listed for extended periods of time. Exposure to such conditions can adversely impact product reliability and result in failures not covered by warranty.

Parameter <sup>[1]</sup>	Minimum	Maximum	Unit
VCC to Ground	-	7	V
Input Voltages at DI, DE, $\overline{RE}$	-0.3	$V_{CC} + 0.3$	V
Bus I/O Voltages at A/Y, B/Z, A, B, Y, Z	-9	13	V
Transient Pulse Voltages through 100Ω at A/Y, B/Z, A, B, Y, Z <sup>[2]</sup>	-	±100	V
RO	-0.3	$V_{CC} + 0.3$	V
Short-Circuit Duration at Y, Z	Continuous		
EFT Rating	See <a href="#">EFT Performance</a> .		
ESD Rating	See <a href="#">ESD Performance</a> .		

1. Absolute Maximum ratings mean the device is not damaged if operated under these conditions. It does not guarantee performance.
2. Tested according to TIA/EIA-485-A, Section 4.2.6 (±100V for 15μs at a 1% duty cycle).

#### 3.2 Recommended Operating Conditions

Parameter	Minimum	Maximum	Unit
Supply Voltage	4.5	5.5	V
Temperature Range	-40	+85	°C
Bus Pin Common-Mode Voltage Range	-7	+12	V

#### 3.3 Thermal Information

Thermal Resistance (Typical)	$\theta_{JA}$ (°C/W) <sup>[1]</sup>
8 Ld SOIC	105
8 Ld MSOP	140
10 Ld MSOP	130
14 Ld SOIC	130

1.  $\theta_{JA}$  is measured with the component mounted on a high-effective thermal conductivity test board in free air. See [TB379](#) for details.

Parameter	Minimum	Maximum	Unit
Maximum Junction Temperature (Plastic Package)	-	+150	°C
Maximum Storage Temperature Range	-65	+150	°C
Pb-Free Reflow Profile <sup>[1]</sup>	See <a href="#">TB493</a>		

1. Pb-free PDIPs can be used for through-hole wave solder processing only. They are not intended for use in Reflow solder processing applications.

### 3.4 Electrical Specifications

Test Conditions:  $V_{CC} = 4.5V$  to  $5.5V$ ; unless otherwise specified. Typical values are at  $V_{CC} = 5V$ ,  $T_A = +25^{\circ}C$ [1].

Parameter	Symbol	Test Conditions	Temp (°C)	Min <sup>[2]</sup>	Typ	Max <sup>[2]</sup>	Unit	
<b>DC Characteristics</b>								
Driver Differential Output Voltage (No load)	$V_{OD1}$		Full	-	-	$V_{CC}$	V	
Driver Differential Output Voltage (Loaded)	$V_{OD2}$	$R_L = 100\Omega$ (RS-422) (Figure 3)	Full	2.8	3.6	-	V	
		$R_L = 54\Omega$ (RS-485) (Figure 3)	Full	2.4	3.1	$V_{CC}$	V	
		$R_L = 15\Omega$ (Eight 120 $\Omega$ terminations) <sup>[3]</sup>	+25	-	1.65	-	V	
		$R_L = 60\Omega$ , $-7V \leq V_{CM} \leq 12V$ (Figure 4)	Full	2.4	3	-	V	
Change in Magnitude of Driver Differential Output Voltage	$\Delta V_{OD}$	$R_L = 54\Omega$ or $100\Omega$ (Figure 3)	Full	-	0.01	0.2	V	
Driver Common-Mode Output Voltage	$V_{OC}$	$R_L = 54\Omega$ or $100\Omega$ (Figure 3)	Full	-	-	3.15	V	
Change in Magnitude of Driver Common-Mode Output Voltage	$\Delta V_{OC}$	$R_L = 54\Omega$ or $100\Omega$ (Figure 3)	Full	-	0.01	0.2	V	
Logic Input High Voltage	$V_{IH}$	DE, DI, $\overline{RE}$	Full	2	-	-	V	
Logic Input Low Voltage	$V_{IL}$	DE, DI, $\overline{RE}$	Full	-	-	0.8	V	
DI Input Hysteresis Voltage	$V_{HYS}$		+25	-	100	-	mV	
Logic Input Current	$I_{IN1}$	DE, DI, $\overline{RE}$	Full	-2	-	2	$\mu A$	
Input Current (A, B, A/Y, B/Z)	$I_{IN2}$	DE = 0V, $V_{CC} = 0V$ or $5.5V$	$V_{IN} = 12V$	Full	-	70	125	$\mu A$
			$V_{IN} = -7V$	Full	-75	55	-	$\mu A$
Output Leakage Current (Y, Z) (Full Duplex Versions Only)	$I_{IN3}$	$\overline{RE} = 0V$ , DE = 0V, $V_{CC} = 0V$ or $5.5V$	$V_{IN} = 12V$	Full	-	1	40	$\mu A$
			$V_{IN} = -7V$	Full	-40	-9	-	$\mu A$
Output Leakage Current (Y, Z) in Shutdown Mode (Full Duplex)	$I_{IN4}$	$\overline{RE} = V_{CC}$ , DE = 0V, $V_{CC} = 0V$ or $5.5V$	$V_{IN} = 12V$	Full	-	1	20	$\mu A$
			$V_{IN} = -7V$	Full	-20	-9	-	$\mu A$
Driver Short-Circuit Current, $V_O =$ High or Low	$I_{OSD1}$	DE = $V_{CC}$ , $-7V \leq V_Y$ or $V_Z \leq 12V$ <sup>[4]</sup>	Full	-	-	$\pm 250$	mA	
Receiver Differential Threshold Voltage	$V_{TH}$	$-7V \leq V_{CM} \leq 12V$	Full	-200	-90	-50	mV	
Receiver Input Hysteresis	$\Delta V_{TH}$	$V_{CM} = 0V$	+25	-	20	-	mV	
Receiver Output High Voltage	$V_{OH}$	$I_O = -8mA$ , $V_{ID} = -50mV$	Full	$V_{CC} - 1.2$	4.3	-	V	
Receiver Output Low Voltage	$V_{OL}$	$I_O = -8mA$ , $V_{ID} = -200mV$	Full	-	0.25	0.4	V	
Receiver Output Low Current	$I_{OL}$	$V_O = 1V$ , $V_{ID} = -200mV$	Full	20	28	-	mA	

Test Conditions:  $V_{CC} = 4.5V$  to  $5.5V$ ; unless otherwise specified. Typical values are at  $V_{CC} = 5V$ ,  $T_A = +25^{\circ}C$ [1].

Parameter	Symbol	Test Conditions	Temp (°C)	Min <sup>[2]</sup>	Typ	Max <sup>[2]</sup>	Unit	
Three-State (High Impedance) Receiver Output Current	$I_{OZR}$	$0.4V \leq V_O \leq 2.4V$	Full	-1	0.03	1	$\mu A$	
Receiver Input Resistance	$R_{IN}$	$-7V \leq V_{CM} \leq 12V$	Full	96	160	-	$k\Omega$	
Receiver Short-Circuit Current	$I_{OSR}$	$0V \leq V_O \leq V_{CC}$	Full	$\pm 7$	65	$\pm 85$	$mA$	
<b>Supply Current</b>								
No-Load Supply Current <sup>[5]</sup>	$I_{CC}$	Half duplex versions, $DE = V_{CC}$ , $\overline{RE} = X$ , $DI = 0V$ or $V_{CC}$	Full	-	650	800	$\mu A$	
		All versions, $DE = 0V$ , $\overline{RE} = 0V$ , or full duplex versions, $DE = V_{CC}$ , $\overline{RE} = X$ , $DI = 0V$ or $V_{CC}$	Full	-	550	700	$\mu A$	
Shutdown Supply Current	$I_{SHDN}$	$DE = 0V$ , $\overline{RE} = V_{CC}$ , $DI = 0V$ or $V_{CC}$	Full	-	0.07	3	$\mu A$	
<b>EFT Performance</b>								
RS-485 Pins (A, Y, B, Z, A/Y, B/Z)		IEC61000-4-4, Electrical Fast Transient Immunity	5kHz	+25		$\pm 5$	$kV$	
			100kHz	+25		$\pm 5$	$kV$	
<b>ESD Performance</b>								
RS-485 Pins (A, Y, B, Z, A/Y, B/Z)		IEC61000-4-2, Air-Gap Discharge Method	Half duplex	+25	-	$\pm 16.5$	-	$kV$
			Full duplex	+25	-	$\pm 10$	-	$kV$
		IEC61000-4-2, Contact Discharge Method		+25	-	$\pm 9$	-	$kV$
		Human Body Model, from bus pins to GND		+25	-	$\pm 16.5$	-	$kV$
All Pins		Human Body Model, per MIL-STD-883 Method 3015		+25	-	$\pm 7$	-	$kV$
		Charged Device Model per JS-002-2014		+25	-	1250	-	$V$
		Machine Model per JESD22-A115C		+25	-	400	-	$V$
<b>Driver Switching Characteristics (115kbps Versions; RAA788150, RAA788152)</b>								
Driver Differential Output Delay	$t_{PLH}, t_{PHL}$	$R_{DIFF} = 54\Omega$ , $C_L = 100pF$ (Figure 5)	Full	500	970	1300	ns	
Driver Differential Output Skew	$t_{SKEW}$	$R_{DIFF} = 54\Omega$ , $C_L = 100pF$ (Figure 5)	Full	-	12	50	ns	
Driver Differential Rise or Fall Time	$t_R, t_F$	$R_{DIFF} = 54\Omega$ , $C_L = 100pF$ (Figure 5)	Full	700	1100	1600	ns	
Maximum Data Rate	$f_{MAX}$	$C_D = 820pF$ <sup>[6]</sup> (Figure 7)	Full	115.2	2000	-	kbps	
Driver Enable to Output High	$t_{ZH}$	$R_L = 500\Omega$ , $C_L = 100pF$ , $SW = GND$ <sup>[7]</sup> (Figure 6)	Full	-	300	600	ns	

Test Conditions:  $V_{CC} = 4.5V$  to  $5.5V$ ; unless otherwise specified. Typical values are at  $V_{CC} = 5V$ ,  $T_A = +25^{\circ}C$ [1].

Parameter	Symbol	Test Conditions	Temp (°C)	Min <sup>[2]</sup>	Typ	Max <sup>[2]</sup>	Unit
Driver Enable to Output Low	$t_{ZL}$	$R_L = 500\Omega$ , $C_L = 100pF$ , SW = $V_{CC}$ <sup>[7]</sup> (Figure 6)	Full	-	130	500	ns
Driver Disable from Output Low	$t_{LZ}$	$R_L = 500\Omega$ , $C_L = 15pF$ , SW = $V_{CC}$ (Figure 6)	Full	-	50	65	ns
Driver Disable from Output High	$t_{HZ}$	$R_L = 500\Omega$ , $C_L = 15pF$ , SW = GND (Figure 6)	Full	-	35	60	ns
Time to Shutdown	$t_{SHDN}$	[8]	Full	60	160	600	ns
Driver Enable from Shutdown to Output High	$t_{ZH(SHDN)}$	$R_L = 500\Omega$ , $C_L = 100pF$ , SW = GND <sup>[8][9]</sup> (Figure 6)	Full	-	-	250	ns
Driver Enable from Shutdown to Output Low	$t_{ZL(SHDN)}$	$R_L = 500\Omega$ , $C_L = 100pF$ , SW = $V_{CC}$ <sup>[8][9]</sup> (Figure 6)	Full	-	-	250	ns
<b>Driver Switching Characteristics (1Mbps Versions; RAA788153, RAA788155)</b>							
Driver Differential Output Delay	$t_{PLH}$ , $t_{PHL}$	$R_{DIFF} = 54\Omega$ , $C_L = 100pF$ (Figure 5)	Full	150	270	400	ns
Driver Differential Output Skew	$t_{SKEW}$	$R_{DIFF} = 54\Omega$ , $C_L = 100pF$ (Figure 5)	Full	-	3	10	ns
Driver Differential Rise or Fall Time	$t_R$ , $t_F$	$R_{DIFF} = 54\Omega$ , $C_L = 100pF$ (Figure 5)	Full	150	325	450	ns
Maximum Data Rate	$f_{MAX}$	$C_D = 820pF$ <sup>[6]</sup> (Figure 7)	Full	1	8	-	Mbps
Driver Enable to Output High	$t_{ZH}$	$R_L = 500\Omega$ , $C_L = 100pF$ , SW = GND <sup>[7]</sup> (Figure 6)	Full	-	110	200	ns
Driver Enable to Output Low	$t_{ZL}$	$R_L = 500\Omega$ , $C_L = 100pF$ , SW = $V_{CC}$ <sup>[7]</sup> (Figure 6)	Full	-	60	200	ns
Driver Disable from Output Low	$t_{LZ}$	$R_L = 500\Omega$ , $C_L = 15pF$ , SW = $V_{CC}$ (Figure 6)	Full	-	50	65	ns
Driver Disable from Output High	$t_{HZ}$	$R_L = 500\Omega$ , $C_L = 15pF$ , SW = GND (Figure 6)	Full	-	35	60	ns
Time to Shutdown <sup>[8]</sup>	$t_{SHDN}$		Full	60	160	600	ns
Driver Enable from Shutdown to Output High	$t_{ZH(SHDN)}$	$R_L = 500\Omega$ , $C_L = 100pF$ , SW = GND <sup>[8][9]</sup> (Figure 6)	Full	-	-	250	ns
Driver Enable from Shutdown to Output Low	$t_{ZL(SHDN)}$	$R_L = 500\Omega$ , $C_L = 100pF$ , SW = $V_{CC}$ <sup>[8][9]</sup> (Figure 6)	Full	-	-	250	ns
<b>Driver Switching Characteristics (20Mbps Versions; RAA788156, RAA788158)</b>							
Driver Differential Output Delay	$t_{PLH}$ , $t_{PHL}$	$R_{DIFF} = 54\Omega$ , $C_L = 100pF$ (Figure 5)	Full	-	21	30	ns
Driver Differential Output Skew	$t_{SKEW}$	$R_{DIFF} = 54\Omega$ , $C_L = 100pF$ (Figure 5)	Full	-	0.2	3	ns
Driver Differential Rise or Fall Time	$t_R$ , $t_F$	$R_{DIFF} = 54\Omega$ , $C_L = 100pF$ (Figure 5)	Full	-	12	16	ns
Maximum Data Rate	$f_{MAX}$	$C_D = 470pF$ <sup>[6]</sup> (Figure 7)	Full	20	55	-	Mbps
Driver Enable to Output High	$t_{ZH}$	$R_L = 500\Omega$ , $C_L = 100pF$ , SW = GND <sup>[7]</sup> (Figure 6)	Full	-	30	45	ns



Test Conditions:  $V_{CC} = 4.5V$  to  $5.5V$ ; unless otherwise specified. Typical values are at  $V_{CC} = 5V$ ,  $T_A = +25^{\circ}C$ [1].

Parameter	Symbol	Test Conditions	Temp (°C)	Min <sup>[2]</sup>	Typ	Max <sup>[2]</sup>	Unit
Driver Enable to Output Low	$t_{ZL}$	$R_L = 500\Omega$ , $C_L = 100pF$ , $SW = V_{CC}$ <sup>[7]</sup> (Figure 6)	Full	-	28	45	ns
Driver Disable from Output Low	$t_{LZ}$	$R_L = 500\Omega$ , $C_L = 15pF$ , $SW = V_{CC}$ (Figure 6)	Full	-	50	65	ns
Driver Disable from Output High	$t_{HZ}$	$R_L = 500\Omega$ , $C_L = 15pF$ , $SW = GND$ (Figure 6)	Full	-	38	60	ns
Time to Shutdown <sup>[8]</sup>	$t_{SHDN}$		Full	60	160	600	ns
Driver Enable from Shutdown to Output High	$t_{ZH(SHDN)}$	$R_L = 500\Omega$ , $C_L = 100pF$ , $SW = GND$ <sup>[8][9]</sup> (Figure 6)	Full	-	-	200	ns
Driver Enable from Shutdown to Output Low	$t_{ZL(SHDN)}$	$R_L = 500\Omega$ , $C_L = 100pF$ , $SW = V_{CC}$ <sup>[8][9]</sup> (Figure 6)	Full	-	-	200	ns
<b>Receiver Switching Characteristics (115kbps and 1Mbps Versions; RAA788150 through RAA788155)</b>							
Maximum Data Rate <sup>[6]</sup>	$f_{MAX}$	(Figure 8)	Full	1	12	-	Mbps
Receiver Input to Output Delay	$t_{PLH}$ , $t_{PHL}$	(Figure 8)	Full	-	100	150	ns
Receiver Skew   $t_{PLH} - t_{PHL}$	$t_{SKD}$	(Figure 8)	Full	-	4	10	ns
Receiver Enable to Output Low	$t_{ZL}$	$R_L = 1k\Omega$ , $C_L = 15pF$ , $SW = V_{CC}$ <sup>[10]</sup> (Figure 9)	Full	-	9	20	ns
Receiver Enable to Output High	$t_{ZH}$	$R_L = 1k\Omega$ , $C_L = 15pF$ , $SW = GND$ <sup>[10]</sup> (Figure 9)	Full	-	7	20	ns
Receiver Disable from Output Low	$t_{LZ}$	$R_L = 1k\Omega$ , $C_L = 15pF$ , $SW = V_{CC}$ (Figure 9)	Full	-	8	15	ns
Receiver Disable from Output High	$t_{HZ}$	$R_L = 1k\Omega$ , $C_L = 15pF$ , $SW = GND$ (Figure 9)	Full	-	8	15	ns
Time to Shutdown <sup>[8]</sup>	$t_{SHDN}$		Full	60	160	600	ns
Receiver Enable from Shutdown to Output High	$t_{ZH(SHDN)}$	$R_L = 1k\Omega$ , $C_L = 15pF$ , $SW = GND$ (Figure 9) <sup>[8][11]</sup>	Full	-	-	200	ns
Receiver Enable from Shutdown to Output Low	$t_{ZL(SHDN)}$	$R_L = 1k\Omega$ , $C_L = 15pF$ , $SW = V_{CC}$ (Figure 9) <sup>[8][11]</sup>	Full	-	-	200	ns
<b>Receiver Switching Characteristics (20Mbps Versions; RAA788156, RAA788158)</b>							
Maximum Data Rate <sup>[6]</sup>	$f_{MAX}$	(Figure 8)	Full	20	30	-	Mbps
Receiver Input to Output Delay	$t_{PLH}$ , $t_{PHL}$	(Figure 8)	Full	-	33	45	ns
Receiver Skew   $t_{PLH} - t_{PHL}$	$t_{SKD}$	(Figure 8)	Full	-	2.5	5	ns
Receiver Enable to Output Low	$t_{ZL}$	$R_L = 1k\Omega$ , $C_L = 15pF$ , $SW = V_{CC}$ <sup>[10]</sup> (Figure 9)	Full	-	8	15	ns
Receiver Enable to Output High	$t_{ZH}$	$R_L = 1k\Omega$ , $C_L = 15pF$ , $SW = GND$ <sup>[10]</sup> (Figure 9)	Full	-	7	15	ns
Receiver Disable from Output Low	$t_{LZ}$	$R_L = 1k\Omega$ , $C_L = 15pF$ , $SW = V_{CC}$ (Figure 9)	Full	-	8	15	ns
Receiver Disable from Output High	$t_{HZ}$	$R_L = 1k\Omega$ , $C_L = 15pF$ , $SW = GND$ (Figure 9)	Full	-	8	15	ns

Test Conditions:  $V_{CC} = 4.5V$  to  $5.5V$ ; unless otherwise specified. Typical values are at  $V_{CC} = 5V$ ,  $T_A = +25^{\circ}C$ <sup>[1]</sup>.

Parameter	Symbol	Test Conditions	Temp (°C)	Min <sup>[2]</sup>	Typ	Max <sup>[2]</sup>	Unit
Time to Shutdown <sup>[8]</sup>	$t_{SHDN}$		Full	60	160	600	ns
Receiver Enable from Shutdown to Output High	$t_{ZH(SHDN)}$	$R_L = 1k\Omega$ , $C_L = 15pF$ , SW = GND <sup>[8][11]</sup> (Figure 9)	Full	-	-	200	ns
Receiver Enable from Shutdown to Output Low	$t_{ZL(SHDN)}$	$R_L = 1k\Omega$ , $C_L = 15pF$ , SW = $V_{CC}$ <sup>[8][11]</sup> (Figure 9)	Full	-	-	200	ns

- All currents in to device pins are positive; all currents out of device pins are negative. All voltages are referenced to device ground unless otherwise specified.
- Parameters with MIN and/or MAX limits are 100% tested at  $+25^{\circ}C$ , unless otherwise specified. Temperature limits established by characterization and are not production tested.
- See Figure 11 for more information and for performance over temperature.
- Applies to peak current. See Typical Performance Curves for more information.
- Supply current specification is valid for loaded drivers when  $DE = 0V$ .
- Limits established by characterization and are not production tested.
- Keep  $\overline{RE} = 0$  to prevent the device from entering SHDN.
- Transceivers are put into shutdown by bringing  $\overline{RE}$  high and DE low. If the inputs are in this state for less than 60ns, the parts are ensured not to enter shutdown. If the inputs are in this state for at least 600ns, the parts are ensured to have entered shutdown. See Low Current Shutdown Mode.
- Keep  $\overline{RE} = V_{CC}$ , and set the DE signal low time  $>600ns$  to ensure that the device enters SHDN.
- The  $\overline{RE}$  signal high time must be short enough (typically  $<100ns$ ) to prevent the device from entering SHDN.
- Set the  $\overline{RE}$  signal high time  $>600ns$  to ensure that the device enters SHDN.

## 4. Test Circuits and Waveforms

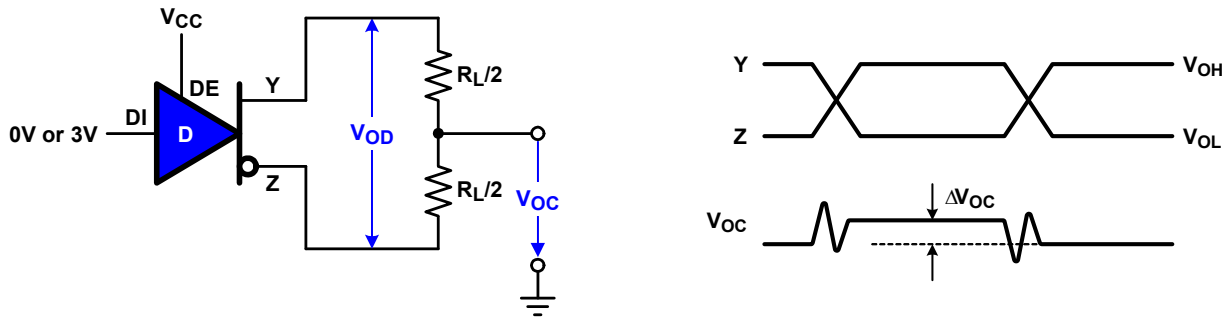

Figure 3. Measurement of Driver Differential Output Voltage with Differential Load



Figure 4. Measurement of Driver Differential Output Voltage with Common-Mode Load

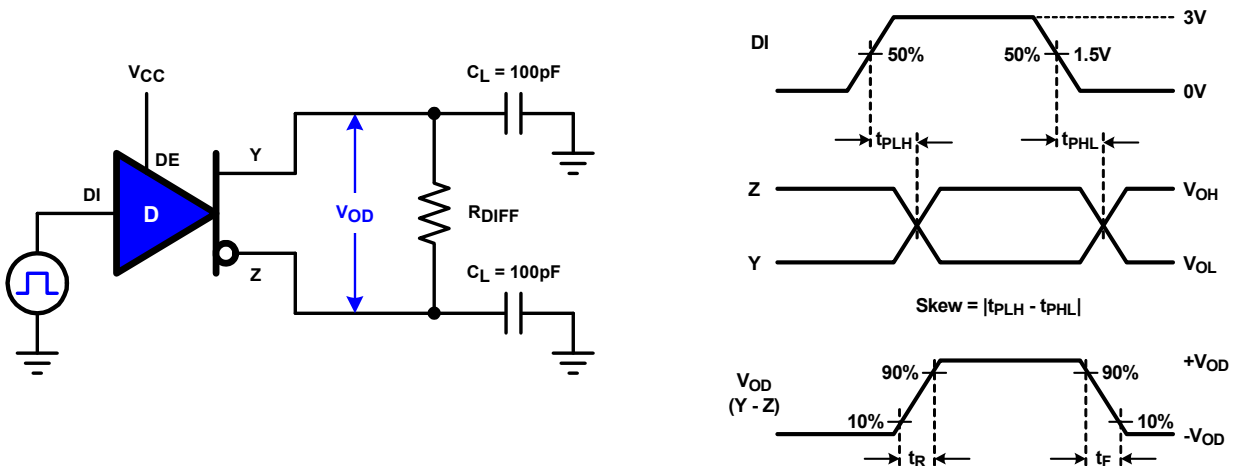

Figure 5. Measurement of Driver Propagation Delay and Differential Transition Times

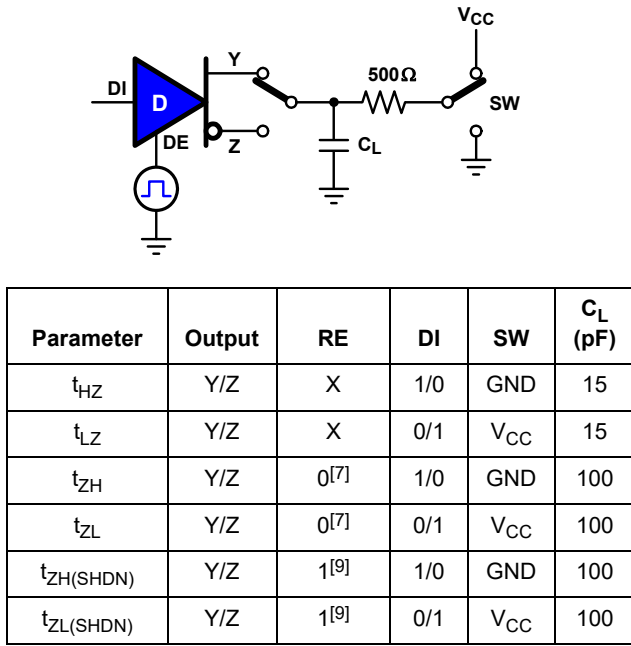

Figure 6. Measurement of Driver Enable and Disable Times

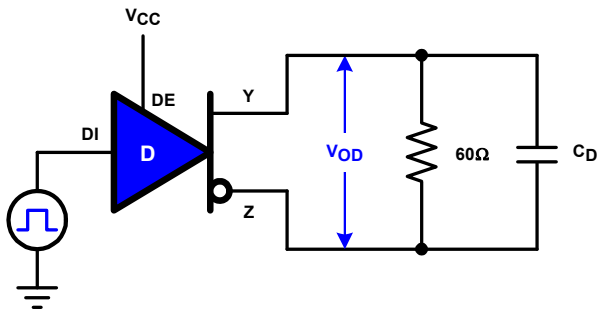
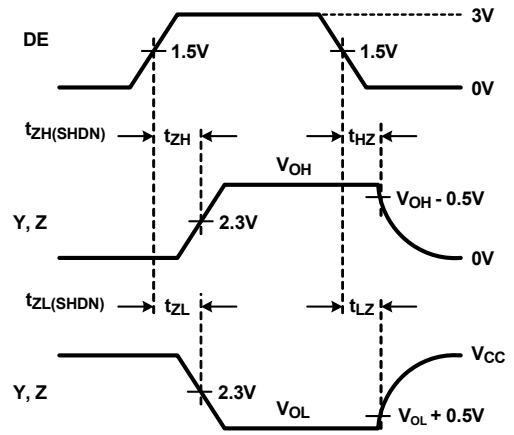

Figure 7. Measurement of Driver Data Rate

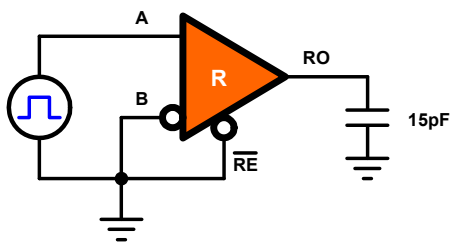
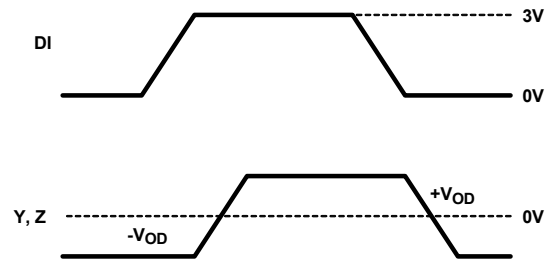
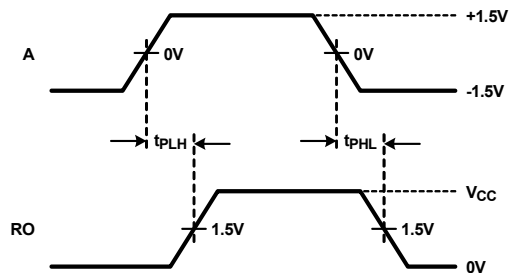
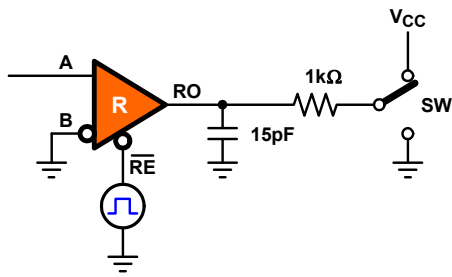

Figure 8. Measurement of Receiver Propagation Delay and Data Rate





Parameter	DE	A	SW
$t_{HZ}$	0	+1.5V	GND
$t_{LZ}$	0	-1.5V	$V_{CC}$
$t_{ZH}^{[10]}$	0	+1.5V	GND
$t_{ZL}^{[10]}$	0	-1.5V	$V_{CC}$
$t_{ZH(SHDN)}^{[11]}$	0	+1.5V	GND
$t_{ZL(SHDN)}^{[11]}$	0	-1.5V	$V_{CC}$

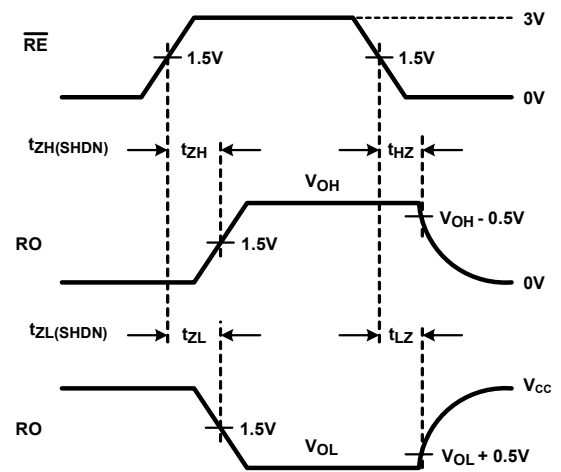

Figure 9. Measurement of Receiver Enable and Disable Times

## 5. Typical Performance Curves

$V_{CC} = 5V$ ,  $T_A = +25^\circ C$ ; Unless otherwise specified

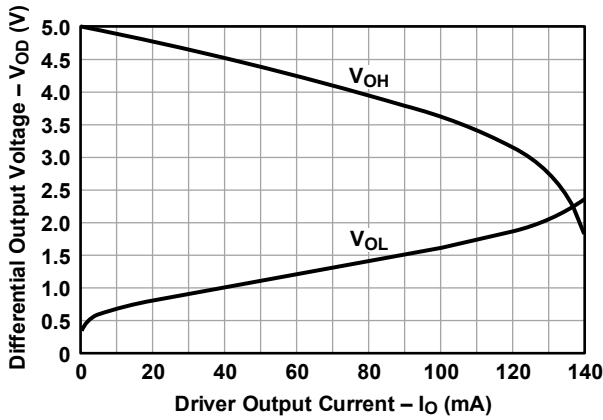

Figure 10. Driver Output High and Low Voltages vs Output Current

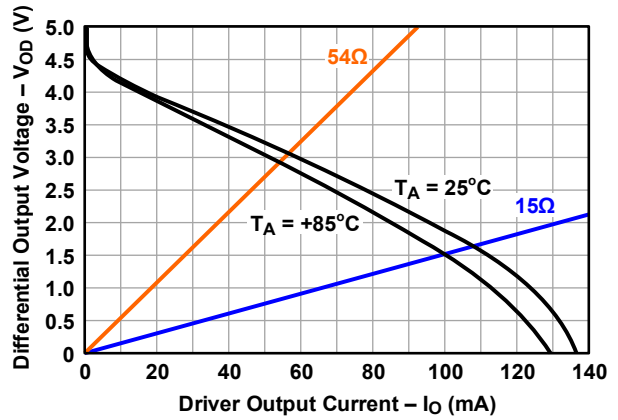

Figure 11. Driver Differential Output Voltage vs Output Current



Figure 12. Driver Output Voltages vs Common-Mode Voltage



Figure 13. Driver Differential Output Voltage vs Temperature



Figure 14. Driver Output Voltage vs Supply Voltage

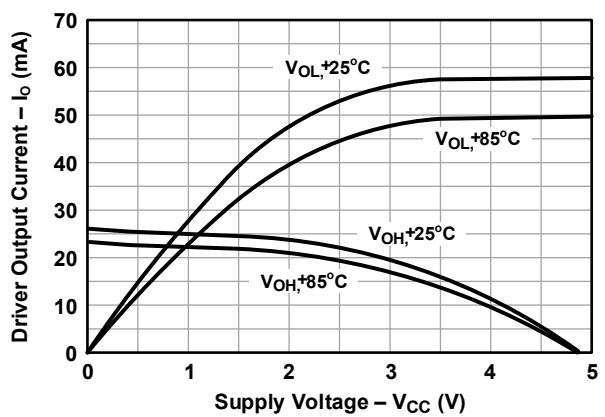

Figure 15. Receiver Output Voltage vs Output Current

$V_{CC} = 5V$ ,  $T_A = +25^{\circ}C$ ; Unless otherwise specified (Cont.)



Figure 16. Supply Current vs Data Rate (RAA788150, RAA788152)

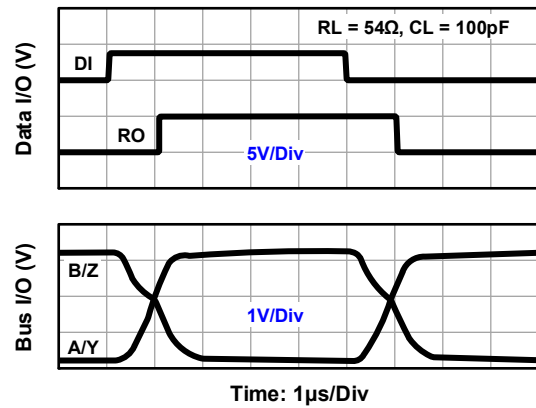

Figure 17. Waveforms (RAA788150, RAA788152)

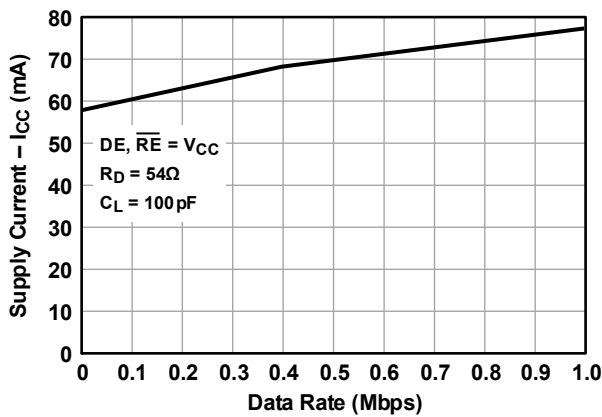

Figure 18. Supply Current vs Data Rate (RAA788153, RAA788155)

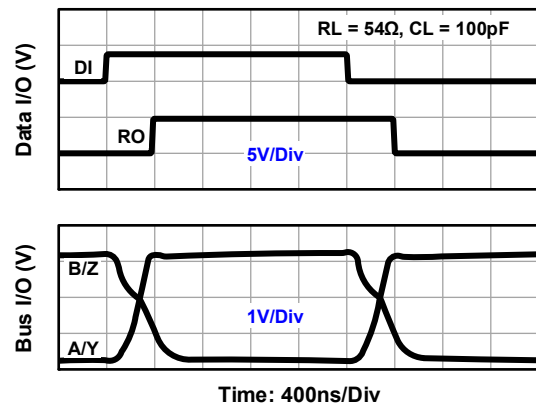

Figure 19. Waveforms (RAA788153, RAA788155)

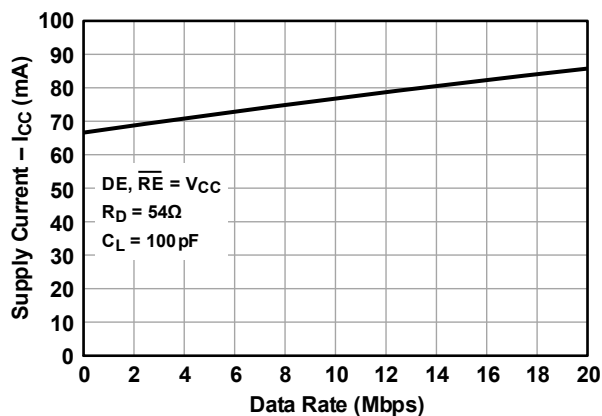

Figure 20. Supply Current vs Data Rate (RAA788156, RAA788158)

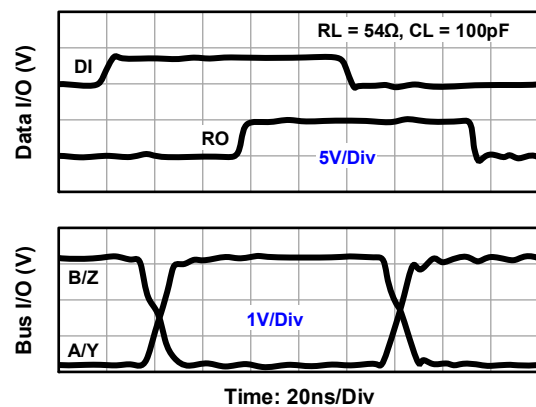

Figure 21. Waveforms (RAA788156, RAA788158)

## 6. Device Description

### 6.1 Overview

The RAA788150, RAA788153, and RAA788156 are full-duplex RS-485 transceivers, and the RAA788152, RAA788155, and RAA788158 are half-duplex RS-485 transceivers. All transceivers feature a large output signal swing that is 60% higher than standard compliant transceivers. The devices are available in three speed grades suitable for data transmission up to 115kbps, 1Mbps, and 20Mbps.

Each transceiver has an active-high driver enable and an active-low receiver enable function. A shutdown current as low as 70nA can be accomplished by disabling both the driver and receiver for more than 600ns.

### 6.2 Functional Block Diagram

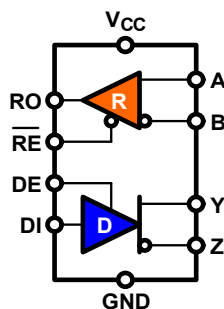

Figure 22. Block Diagram  
RAA788150, RAA788153, RAA788156

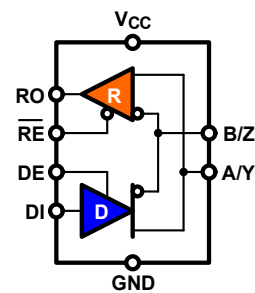

Figure 23. Block Diagram  
RAA788152, RAA788155, RAA788158

### 6.3 Operating Modes

#### 6.3.1 Driver Operation

A logic high at the driver enable pin, DE, activates the driver and causes the differential driver outputs, Y and Z, to follow the logic states at the data input, DI.

A logic high at DI causes Y to turn high and Z to turn low. In this case, the differential output voltage, defined as  $V_{OD} = V_Y - V_Z$ , is positive. A logic low at DI reverses the output states reverse, turning Y low and Z high, therefore making  $V_{OD}$  negative.

A logic low at DE disables the driver, making Y and Z high-impedance. In this condition, the logic state at DI is irrelevant. To ensure the driver remains disabled after device power-up, Renesas recommends connecting DE through a 1kΩ to 10kΩ pull-down resistor to ground.

Table 1. Driver Truth Table

Inputs			Outputs		Function
RE	DE	DI	Y	Z	
X	H	H	H	L	Actively drives bus high
X	H	L	L	H	Actively drives bus low
L	L	X	Z	Z	Driver disabled, outputs high-impedance
H	L	X	Z*	Z*	Shutdown mode: driver and receiver disabled for more than 600ns

Note: See Shutdown mode explanation in [Low Current Shutdown Mode](#).



### 6.3.2 Receiver Operation

A logic low at the receiver enable pin,  $\overline{RE}$ , activates the receiver and causes its output, RO, to follow the bus voltage at the differential receiver inputs, A and B. Here, the bus voltage is defined as  $V_{AB} = V_A - V_B$ .

For  $V_{AB} \geq -0.05V$ , RO turns high, and for  $V_{AB} \leq -0.2V$ , RO turns low. For input voltages between -50mV and -200mV, the state of RO is undetermined; therefore, it could be high or low.

A logic high at  $\overline{RE}$  disables the receiver, making RO high-impedance. In this condition, the polarity and magnitude of the input voltage is irrelevant. To ensure the receiver output remains high when the receiver is disabled, it is recommended to connect RO, using a 1kΩ to 10kΩ pull-up resistor to VCC.

To enable the receiver to immediately monitor the bus traffic after device power-up, connect  $\overline{RE}$  through a 1kΩ to 10kΩ pull-down resistor to ground.

Table 2. Receiver Truth Table

Inputs			Outputs	Function
RE	DE	A – B	RO	
L	X	$V_{AB} \geq -0.05V$	H	RO is data-driven high
L	X	$-0.05V > V_{AB} > -0.2V$	Undetermined	Actively drives bus low
L	X	$V_{AB} \leq -0.2V$	L	RO is data-driven low
L	X	Inputs Open/Shorted	H	RO is failsafe-high
H	H	X	Z	Receiver disabled, RO is high-impedance
H	L	X	Z*	Shutdown mode: driver and receiver disabled for more than 600ns

Note: See Shutdown mode explanation in [Low Current Shutdown Mode](#).

### 6.4 Device Features

#### 6.4.1 Large Output Signal Swing

The RAA78815x family has a 60% larger differential output voltage swing than standard RS-485 transceivers. It delivers a minimum  $V_{OD}$  of 2.4V across a 54Ω differential load, or 1.65V across a 15Ω differential load. Figure 24 shows that the  $V_{OD}$  at 54Ω is more than 50% higher than that of a standard transceiver.

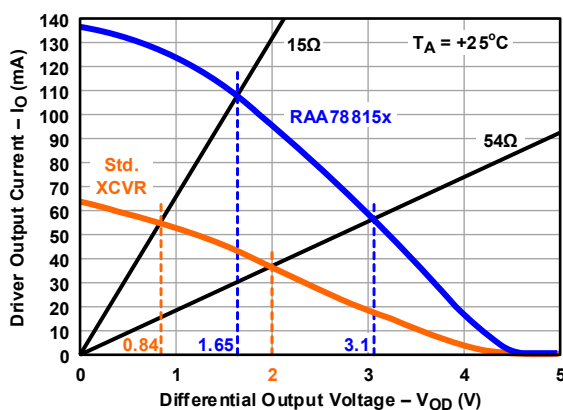
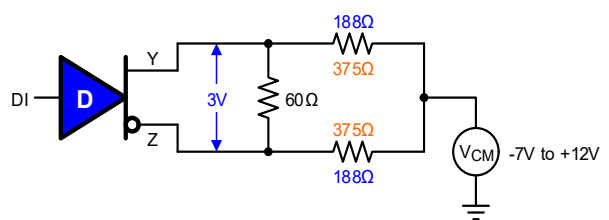

Figure 24. V-I Characteristic of RAA78815x vs Standard RS-485 Transceiver



Device	R <sub>CM</sub> (Ω)	1UL (Ω)	# UL	1/8UL (Ω)	# Devices on Bus
Std. RS-485	375	12k	32	96k	256
RAA78815x	188	12k	64	96k	512

Figure 25. Unit Load and Transceiver Drive of RAA78815x vs Standard RS-485 Transceiver

Figure 25 compares the maximum number of unit loads and bus transceivers when choosing an RAA78815x over a standard transceiver. The RS-485 standard specifies a minimum total common-mode load resistance of  $R_{CM} = 375\Omega$  between each signal conductor and ground. Because one unit load (1UL) is equivalent to  $12k\Omega$ , the total common-mode resistance of  $375\Omega$  yields  $12k\Omega/375\Omega = 32ULs$ .

For an RAA78815x transceiver however,  $R_{CM}$  can be as small as  $188\Omega$ , resulting in a total common-mode load of  $12k\Omega/188\Omega = 64ULs$ . This means the driver of an RAA78815x transceiver can drive up to  $64 \times 1UL$  transceivers or  $512 \times 1/8UL$  transceivers.

The advantages of such superior drive capability are as follows:

- Up to 900mV higher noise immunity (2.4V vs 1.5V  $V_{OD}$ )
- Up to twice the maximum cable length of standard transceivers (~8000ft vs 4000ft)
- The design of star configurations or other multi-terminated nonstandard network topologies

### 6.4.2 Driver Overload Protection

The RS-485 specification requires drivers to survive worst case bus contentions undamaged. The RAA78815x transceivers meet this requirement through driver output short-circuit current limits and on-chip thermal shutdown circuitry.

The driver output stages incorporate short-circuit current limiters that ensure that the output current never exceeds the RS-485 specification, even at the common-mode voltage range extremes.

In the event of a major short-circuit conditions, the devices also include a thermal shutdown feature that disables the drivers whenever the temperature becomes excessive. This eliminates the power dissipation, allowing the die to cool. The drivers automatically re-enable after the die temperature drops about  $15^{\circ}C$ . If the contention persists, the thermal shutdown/re-enable cycle repeats until the fault is cleared. The receivers stay operational during thermal shutdown.

### 6.4.3 Full-Failsafe Receiver

The differential receivers of the RAA78815x family are full-failsafe, meaning their outputs turn logic high when:

- The receiver inputs are open (floating) because of a faulty bus node connector
- The receiver inputs are shorted because of an insulation break of the bus cable
- The receiver input voltage is close to 0V because of a terminated bus not being actively driven

Full-failsafe switching is accomplished by offsetting the maximum receiver input threshold to  $-50mV$ . Figure 26 shows that, in addition to the threshold offset, the receiver also has an input hysteresis,  $\Delta V_{TH}$ , of  $20mV$ . The combination of offset and hysteresis allows the receiver to maintain its output high, even in the presence of  $140mV_{P-P}$  differential noise, without the need for external failsafe biasing resistors.

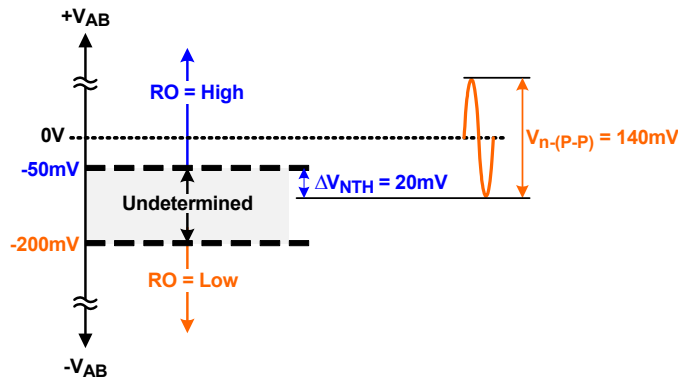

Figure 26. Full-Failsafe Performance with High Noise Immunity

### 6.4.4 Low Current Shutdown Mode

The RAA78815x transceivers use a fraction of the power required by their bipolar counterparts, but also include a shutdown feature that reduces the already low quiescent  $I_{CC}$  to a 70nA trickle. These devices enter shutdown whenever the receiver and the driver are simultaneously disabled ( $\overline{RE} = V_{CC}$  and  $DE = GND$ ) for a period of at least 600ns. Disabling both the driver and the receiver for less than 60ns ensures that the transceiver does not enter shutdown.

**Note:** The driver and receiver enable times increase when the transceiver enables from shutdown. See the footnotes, [1] to [11], in the Electrical Specifications.

### 6.4.5 Hot Plug Function

When the equipment powers up, there is a period of time where the controller driving the RS-485 enable lines is unable to ensure that the driver and receiver outputs are kept disabled. If the equipment is connected to the bus, a driver activating prematurely during power-up may crash the bus. To avoid this scenario, the RAA78815x devices incorporate a Hot Plug function. During power-up and power-down, the Hot Plug function disables the driver and receiver outputs regardless of the states of  $DE$  and  $\overline{RE}$ . When  $V_{CC}$  reaches  $\sim 3.4V$ , the enable pins are released. This gives the controller the chance to stabilize and drive the RS-485 enable lines to the proper states.

### 6.4.6 High EFT Immunity

The bus pins of the RAA78815x transceivers withstand  $\pm 5kV$  Electrical Fast Transient (EFT) immunity per IEC61000-4-4. During the EFT test, the EFT generator produces a burst of 75 fast transients that are capacitively coupled onto RS-485 data lines using a capacitive clamp (Figure 27).

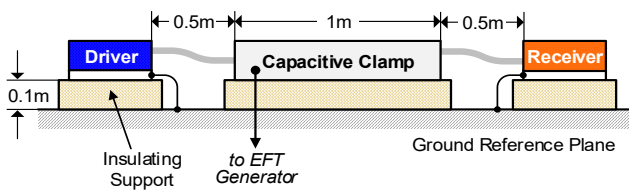

Figure 27. Test Setup with Capacitive Clamp

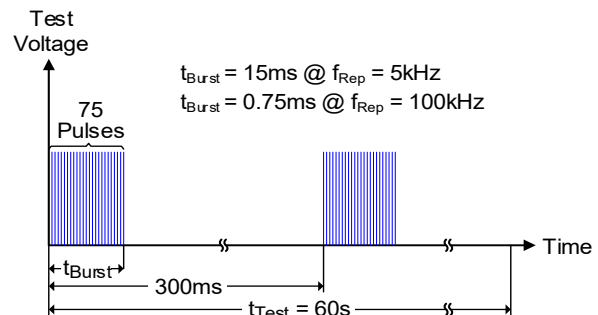

Figure 28. EFT Test Timing

A burst period is 300ms and begins with 75 EFT pulses ( $t_{Burst}$ ) followed by a break interval (Figure 28). Over a test time of 60 seconds minimum, multiple bursts are applied at a predefined repetition frequency of either 5kHz or

100kHz, therefore, unleashing a minimum of 15000 EFT pulses onto the data link. The RAA78815x transceivers have been tested with both repetition frequencies, 5kHz and 100kHz.

In the test setup, a complete RS-485 data link (driver, receiver and unshielded twisted pair cable) has been tested during data transmission. Afterwards, the devices were tested on an automatic test system (ATE) for parametric performance. The ATE pass criterion requires that a device shows no parametric shift at all.

All RAA78815x transceivers passed the EFT tests with ±5kV test voltage, the highest possible test voltage of an AXOS-5 test system, which places this transceiver family into the highest special test level category of the IEC61000-4-4 standard (Table 3, Test Level X).

Table 3. EFT Test Level Category for RAA78815x Transceivers

Test Level	Test Voltage (kV)	Repetition Frequency (kHz)	Components Passing
1	0.25	5 and 100	RAA788150, RAA188152, RAA788153, RAA188155, RAA788156, RAA188158
2	0.5	5 and 100	
3	1	5 and 100	
4	2	5 and 100	
X	5	5 and 100	

### 6.4.7 High ESD Protection

The bus pins of the RAA78815x transceivers have on-chip ESD protection against ±16.5kV HBM, ±9kV contact, and ±16.5kV air-discharge according to IEC61000-4-2. The difference between the HBM and IEC ESD ratings lies in the test severity, as both standards aim for different application environments.

HBM ESD ratings are component level ratings, used in semiconductor manufacturing in which component handling can cause ESD damage to a single device. Because component handling is performed in a controlled ESD environment, the ESD stress on a component is drastically reduced. These factors make the HBM test the less severe ESD test.

IEC ESD ratings are system level ratings. These are required in the uncontrolled field environment, where for example, a charged end-user can subject handheld equipment to ESD levels of more than 40kV by touching connector pins when plugging or unplugging cables.

The main differences between the HBM and the IEC 61000-4-2 standards are the number of strikes applied during testing and the generator models (Figure 29), which create differences in all the waveform rise times and peak currents (Figure 30).

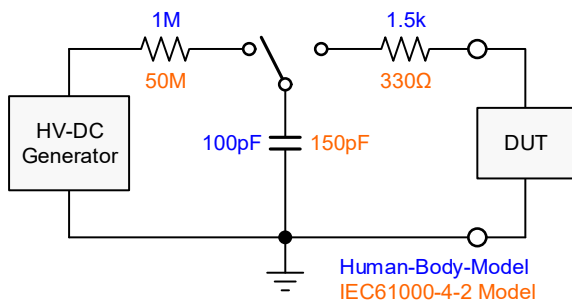

Figure 29. Generator Models for HBM and IEC ESD Tests



Figure 30. Difference in Rise-time and Charge Currents between HBM and IEC ESD Transients

The IEC model has 50% higher charge capacitance ( $C_S$ ) and 78% lower discharge resistance ( $R_D$ ) than the HBM model, therefore producing shorter transient rise times and higher discharge currents. The ESD ratings of the

RAA78815x transceivers exceed test level 4 of the IEC61000-4-2 standard, which significantly increases equipment robustness.

## 7. Application Information

### 7.1 Network Design

Designing a reliable RS-485 network requires the consideration of a variety of factors that ultimately determine the network performance. These include network topology, cable type, data rate and/or cable length, stub length, distance between network nodes, and line termination.

The main difference between network designs is dictated by their modes of data exchange between bus nodes, which can be half-duplex or full-duplex (Figure 31 and Figure 32).

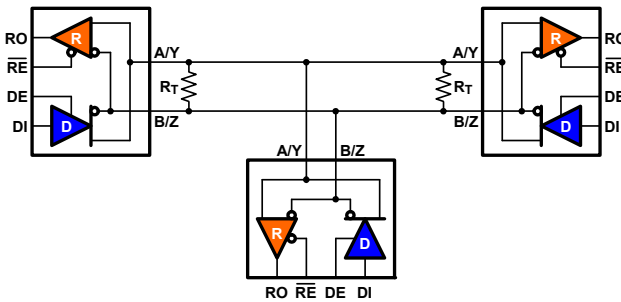

Figure 31. Half-Duplex Bus

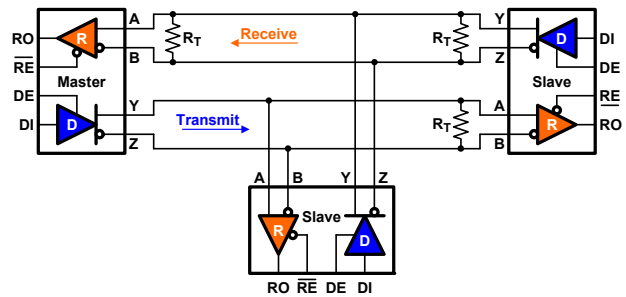

Figure 32. Full-Duplex Bus

**Half-duplex networks** use only a single signal-pair of cables between one master node and multiple slave nodes, allowing the nodes to either transmit or receive data, but never both at the same time. This reduced cabling effort makes these networks well suited for covering long distances of up to several thousands of feet. To maintain high signal integrity, the applied data rates range from as low as 9.6kbps up to 115kbps. This requires transceivers with long driver output transition times, typically in the range of microseconds, to ensure low EMI in the presence of large cable inductances.

To prevent signal reflections of the bus lines, each cable end must be terminated with a resistor,  $R_T$ , and this value should match the characteristic cable impedance,  $Z_0$ .

**Full-duplex networks**, on the other hand, aim for high data throughput. These networks use two signal-pairs to support the simultaneous transmitting and receiving of data. The signal pair denoted as the transmit path connects the driver output of the master node to the receiver inputs of multiple slave nodes. The other pair connects the driver outputs of the slave nodes with the receiver input of the master node.

Because the data flow in the transmit path is unidirectional, the transmit path requires only one termination at the remote cable end, opposite the master node. However, data flow in the receive path is bidirectional; therefore, it requires line termination at both cable ends. Typically, high data throughput also calls for higher data rates in the 1Mbps to 10Mbps range. As cable losses increase with frequency, most full-duplex networks are limited to shorter bus cable lengths of a few hundred feet to maintain signal integrity.

The following sections describe the parameters, previously mentioned, that impact network performance. This discussion applies to both half-and full-duplex network designs.

#### 7.1.1 Cable Type

RS-485 networks use differential signaling over twisted pair cable. The conductors of a twisted pair are equally exposed to external noise. They pick up noise and other electromagnetically induced voltages as common-mode signals, which are effectively rejected by the differential receivers.

For best performance, use industrial RS-485 cables that are of the sheathed, shielded, twisted pair type, (STP), with a characteristic impedance of 120Ω and conductor sizes of 22 to 24 AWG (equivalent to diameters of 0.65mm and 0.51mm, respectively). They are available in single, two, and four signal-pair versions to accommodate the design of half- and full-duplex systems. Figure 33 shows the cross section and cable parameters of a typical UTP cable.

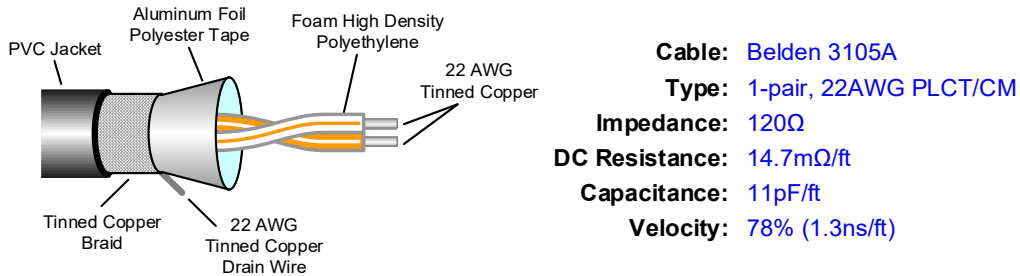

Figure 33. Single Pair STP Cable for RS-485 Applications

### 7.1.2 Cable Length vs Data Rate

RS-485 and RS-422 are intended for network lengths up to 4000ft, but the maximum system data rate decreases as the transmission length increases. Devices operating at 20Mbps are limited to lengths less than 100ft, while the 115kbps versions can operate at full data rates with lengths of several 1000ft. **Note:** RAA78815x transceivers can cover almost twice the distance of standard compliant RS-485 transceivers.

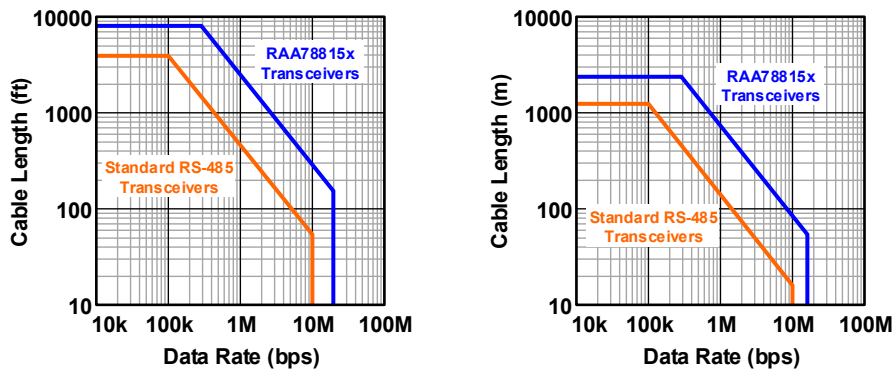

Figure 34. Data Rate vs Cable Length Guidelines in Feet and Meters

### 7.1.3 Topologies and Stub Lengths

RS-485 recommends its nodes to be networked in daisy-chain or backbone topology. In these topologies, the participating drivers, receivers, and transceivers connect to a main cable trunk through “short” stubs. A stub being the actual electrical link between transceiver and cable trunk.

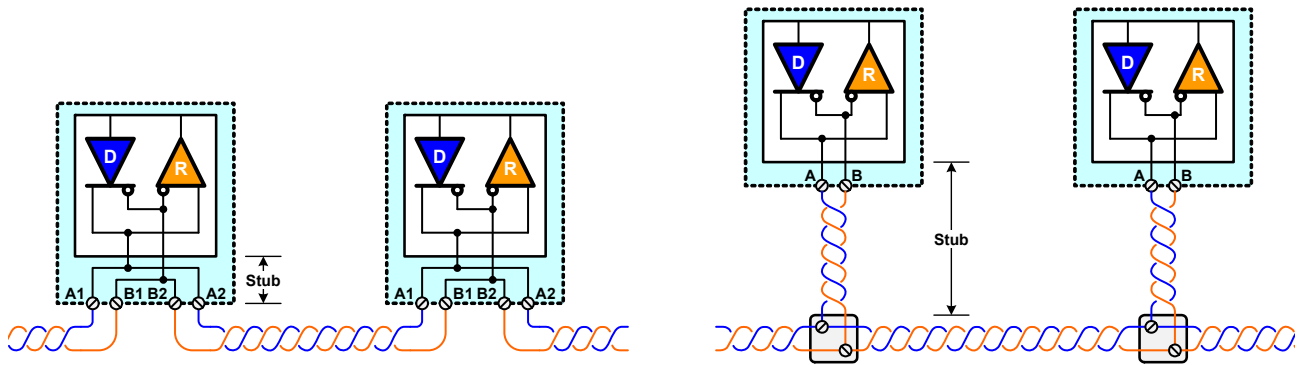

Figure 35. Stub Lengths in Daisy Chain (left) and Backbone (right) Topologies

Because daisy chaining brings the cable trunk much closer to the transceiver bus terminals than a backbone design, the stub lengths between the two topologies can differ significantly. To prevent the bus from being overloaded by line terminations, stubs are never terminated. A stub therefore, represents a piece of unterminated transmission line. To eliminate signal reflections on the stub line, you should keep its propagation delay below 1/5 of the driver output rise time, leading to the maximum stub length of:

(EQ. 1) 
$$L_{\text{Stub}} = v \cdot c \cdot \frac{t_r}{5}$$

where

- c is the speed of light (m/s)
- v is the signal velocity in the cable, expressed as a factor of c
- $t_r$  is the rise time of the driver output (ns)

Applying Equation 1 to the RAA78815x transceivers assuming a velocity of 78%, results in the maximum stub lengths associated with the corresponding transceivers, as shown in Table 4.

Table 4. Stub Length as Function of Driver Rise Time

Device	Data Rate (Mbps)	Rise Time (ns)	Maximum Stub Length
RAA788150, RAA788152	0.115	1100	168ft (51m)
RAA788153, RAA788155	1	150	23ft (7m)
RAA788156, RAA788158	20	8	1.2ft (0.36m)

Table 4 proves that transceivers with long driver rise times are well suited for applications requiring long stub lengths and low radiated emission in the presence of increased stub inductance.

### 7.1.4 Minimum Distance between Nodes

The electrical characteristics of the RS-485 bus are primarily defined by the distributed inductance and capacitance along the bus cable and printed circuit board traces. Adding capacitance to the bus in the form of transceivers and connectors lowers the line impedance and causes impedance mismatches at the loaded bus section.

Input signals arriving at these mismatches are partially reflected back to the signal source, distorting the driver output signal. Ensuring a valid receiver input voltage during the first signal transition from a driver output anywhere on the bus, requires the bus impedance at the mismatches to be  $Z_{\text{load}} \geq 0.4Z_{\text{nom}}$  or  $0.4 \times 120\Omega = 48\Omega$ . This can be achieved by maintaining a minimum distance between bus nodes of:

(EQ. 2) 
$$D_{\min} \geq \frac{C_L}{5.25 \cdot C_C}$$

where

- $C_L$  is the lumped load capacitance
- $C_C$  is the distributed cable or PCB trace capacitance per unit length.

Figure 36 shows the relationship for the minimum node spacing as a function of  $C_C$  and  $C_L$  graphically. Load capacitance includes contributions from the line circuit bus pins, connector contacts, printed circuit board traces, protection devices, and any other physical connections to the trunk line as long as the distance from the bus to the transceiver, known as the stub, is electrically short.

Putting some values to the individual capacitance contributions: 5V transceivers typically possess a capacitance of 7pF, while 3V transceivers have about twice that capacitance at 16pF. Board traces add about 1.3 to 2pF/in depending on their construction.

Connector and suppression device capacitance can vary widely. Media distributed capacitance ranges from 11pF/ft for low capacitance, unshielded, twisted-pair cable up to 22pF/ft for backplanes.

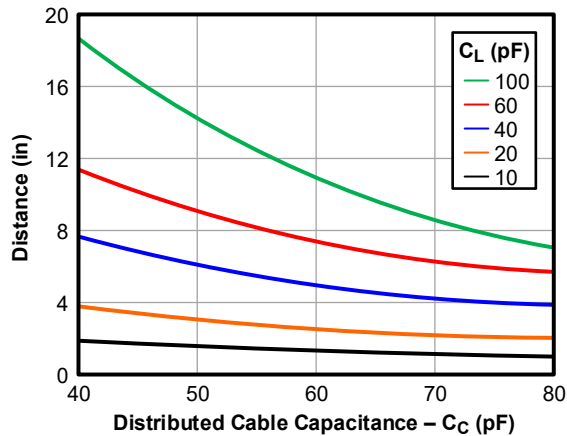

Figure 36. Minimum Distance between Bus Nodes as Function of Cable and Load Capacitance

### 7.1.5 Failsafe Biasing Termination

As mentioned in [Full-Failsafe Receiver](#), the RAA78815x transceivers are full-failsafe and capable of tolerating up to 140mV<sub>P-P</sub> of differential noise on a passive bus without needing external failsafe biasing.

However, in harsh industrial environments, such as the factor floors in industrial automation, the differential noise can reach levels of more than 1V<sub>P-P</sub>. In this case, external fail-safe biasing at the network line terminations is strongly recommended. Here the termination resistors  $R_T$  connect through the biasing resistors  $R_B$  to the supply rails VCC and GND.

Short data links (<100m) only require a single failsafe termination at one cable end, while the other end is terminated with the cable characteristic impedance  $Z_0$  (Figure 37, left circuit).



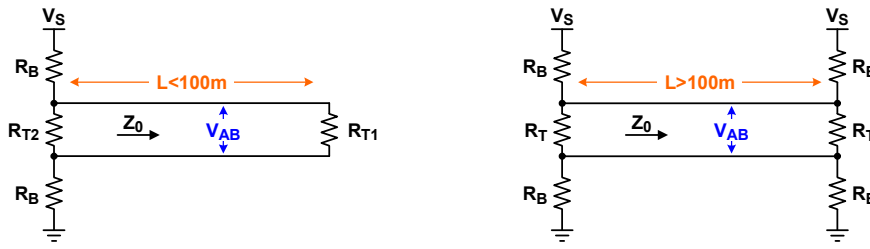

Figure 37. Failsafe Biasing of Short (<100m) and Long (>100m) Data Links

The corresponding resistor values are calculated with [Equation 3](#) to [Equation 5](#).

$$(EQ. 3) \quad R_B = \frac{V_S / V_{AB} + 1}{0.036}$$

$$(EQ. 4) \quad R_{T2} = \frac{R_B \cdot 120\Omega}{R_B - 60\Omega}$$

$$(EQ. 5) \quad R_{T1} = 120\Omega$$

Longer data links (>100m) require two identical failsafe basing networks, one at each cable end, to minimize the differential voltage drop along the bus ([Figure 37](#), right circuit). The resistor values are calculated using [Equation 6](#) and [Equation 7](#):

$$(EQ. 6) \quad R_B = \frac{2V_S / V_{AB} + 1}{0.036}$$

$$(EQ. 7) \quad R_T = \frac{R_B \cdot 120\Omega}{R_B - 60\Omega}$$

[Equation 3](#) to [Equation 7](#) apply to the multi-driver applications of half- and full-duplex networks. For single driver applications, the values of  $R_B$  and  $R_T$  are calculated using [Equation 8](#) and [Equation 9](#).

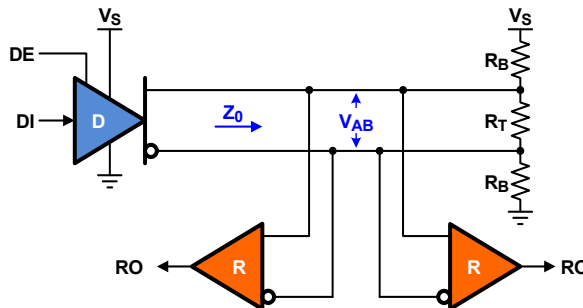

Figure 38. Failsafe Biasing of a Single-Driver Network

(EQ. 8)  $R_B = 60\Omega \cdot \frac{V_S}{V_{AB}}$

(EQ. 9)  $R_T = \frac{R_B \cdot 120\Omega}{R_B - 60\Omega}$

For more details on failsafe biasing, see [TB509](#).

## 7.2 Transient Protection

Although the RAA78815x transceivers have on-chip transient protection circuitry against bursts of Electrical Fast Transients (EFT) and Electrostatic Discharge (ESD), they are vulnerable to surge transients. Surge transients can be caused by lightning strikes or the switching of power systems including load changes and short circuits. Their energy content is up to 8 million times higher than that of ESD transients and therefore, requires the addition of external transient protection.

Because standard RS-485 transceivers have asymmetric stand-off voltages of -9V and +14V, external protection requires a bidirectional Transient Voltage Suppressor (TVS) with asymmetric breakdown voltages. The only device satisfying this requirement is the 400W TVS, SM712.

The SM712 operates across the asymmetrical common-mode voltage range from -7V to +12V. The device protects transceivers against ESD, EFT, and surge transients up to the following levels:

- IEC61000-4-2 (ESD) +15kV (air), +8kV (contact)
- IEC61000-4-4 (EFT) 40A (5/50ns)
- IEC61000-4-5 (Lightning) 12A (8/20µs)

Because the transceiver on-chip protection and the SM712 have a similar switching characteristics, series resistors ( $R_S$ ) are used to prevent the two protection schemes from interacting with one another.

These resistors can be carbon composite or pulse-proof thick-film resistors which should be inserted between the TVS and the transceiver bus terminals to limit the bus currents into the transceiver during a surge event. Their value should be equal to or less than 20Ω to minimize the attenuation of the bus voltage during normal operation.

[Figure 39](#) shows the schematic of a 1kV surge protection example for the RAA788152 and its bill of materials.

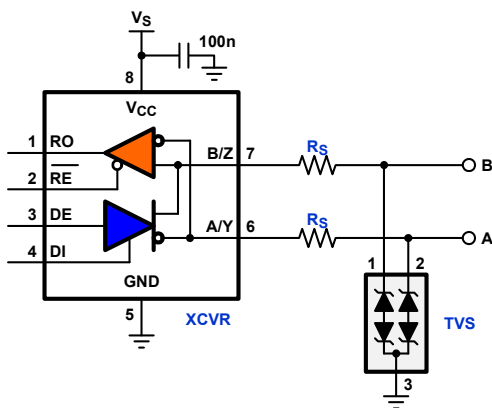

Name	Function	Order No.	Vendor
XCVR	5V, 115kbps transceiver	RAA788152	Renesas
TVS	400W (8,20µs), bidirectional TVS	SM712.TCT	Semtech
RS	10Ω, 0.2W, pulse-proof thick-film resistor	CRCW0603-HP e3 series	Vishay

Figure 39. IEC61000-4-5 Level 2 (1kV) Surge Protection and Associated Bill of Materials

For more information on transient protection, see AN1976, AN1977, AN1978, and AN1979 at the [Renesas website](#).

### 7.3 Layout Guidelines

Because ESD and EFT transients have a wide frequency bandwidth from approximately 3MHz to 3GHz, high-frequency layout techniques must be applied during PCB design.

1. For your PCB design to be successful, start with the design of the protection circuit in mind.
2. Place the protection circuitry close to the bus connector to prevent noise transients from penetrating your board.
3. Use VCC and ground planes to provide low-inductance. High-frequency currents follow the path of least inductance and not the path of least impedance.
4. Design the protection components into the direction of the signal path. Do not force the transient currents to divert from the signal path to reach the protection device.
5. Apply 100nF to 220nF bypass capacitors as close as possible to the VCC pins of the transceiver, UART, and controller ICs on the board.
6. Use at least two vias for VCC and ground connections of bypass capacitors and protection devices to minimize the effective via-inductance.
7. Use 1kΩ to 10kΩ pull-up/down resistors for the transceiver enable lines to limit noise currents into these lines during transient events.
8. Insert pulse-proof resistors into the A and B bus lines if the TVS clamping voltage is higher than the specified maximum voltage of the transceiver bus terminals. These resistors limit the residual clamping current into the transceiver and prevent it from latching up.

#### 7.3.1 Layout Example

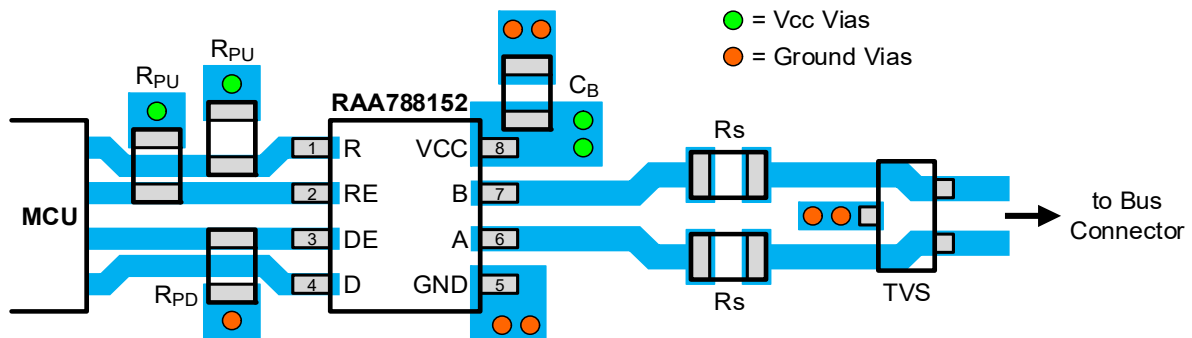

Figure 40. RAA788152 Layout Example

## 8. Package Outline Drawings

For the most recent package outline drawing, see [M8.15](#).

M8.15

8 Lead Narrow Body Small Outline Plastic Package

Rev 7, 9/2023

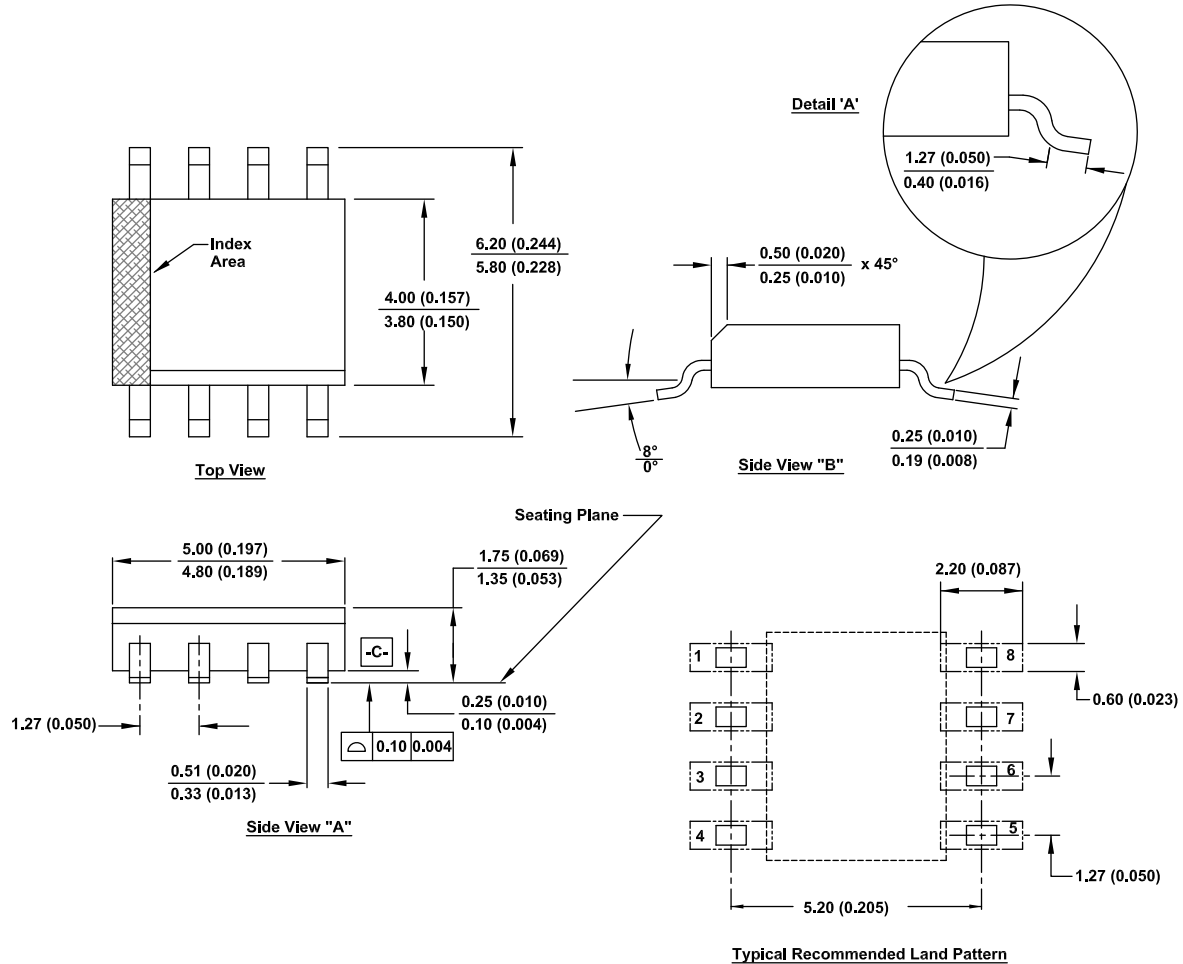

Notes:

1. Dimensioning and tolerancing conform to ASME Y14.5M-1994.
2. Package length does not include mold flash, protrusion or gate burrs. Mold flash, protrusion and gate burrs shall not exceed 0.15mm (0.006 inch) per side.
3. Package width does not include interlead flash or protrusions. Interlead flash and protrusions shall not exceed 0.25mm (0.010 inch) per side.
4. The chamfer on the body is optional. If it is not present, a visual index feature must be located within the crosshatched area.
5. Terminal numbers are shown for reference only.
6. The lead width as measured 0.36mm (0.014 inch) or greater above the seating plane, shall not exceed a maximum value of 0.61mm (0.024 inch)
7. Controlling dimension: MILLIMETER. Converted inch dimension are not necessarily exact.
8. This outline conforms to JEDEC publication MS-012-AA ISSUE C.

For the most recent package outline drawing, see [M8.118](#).

M8.118

8 Lead Mini Small Outline Plastic Package

Rev 5, 5/2021

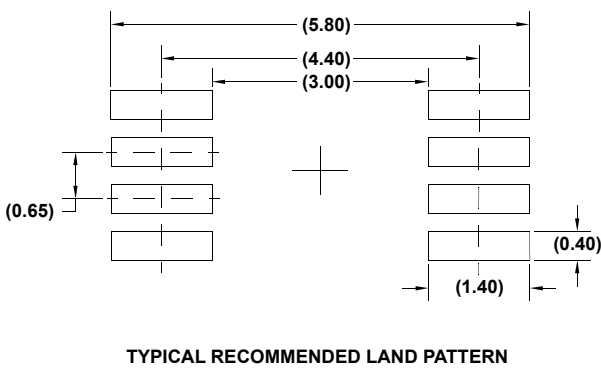
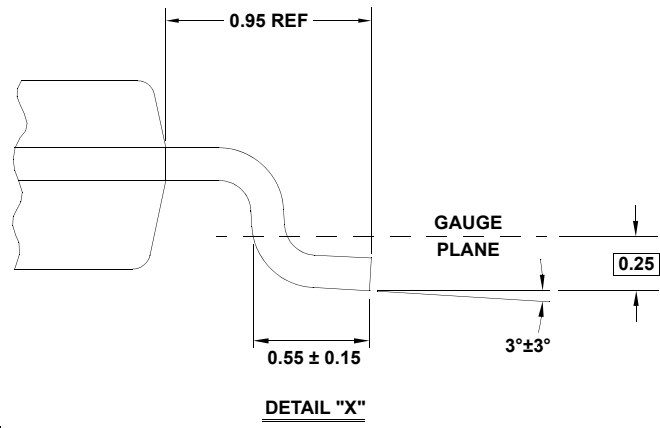

**NOTES:**

1. Dimensions are in millimeters.
2. Dimensioning and tolerancing conform to JEDEC MO-187-AA and AMSEY14.5m-1994.
3. Plastic or metal protrusions of 0.15mm max per side are not included.
4. Plastic interlead protrusions of 0.15mm max per side are not included.
5. Dimensions are measured at Datum Plane "H".
6. Dimensions in ( ) are for reference only.

For the most recent package outline drawing, see [M10.118](#).

M10.118

10 Lead Mini Small Outline Plastic Package

Rev 2, 5/2021

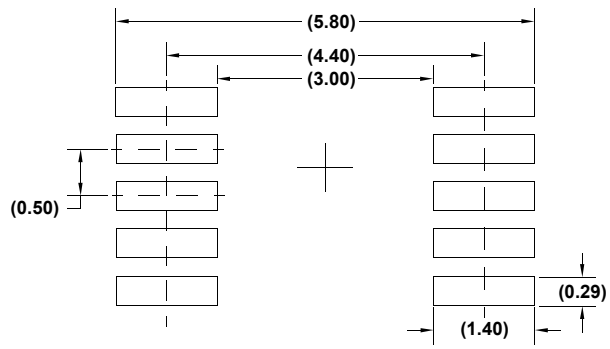
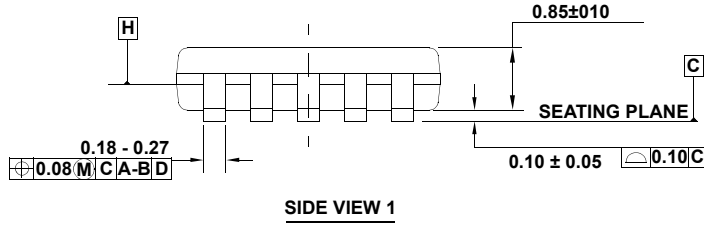
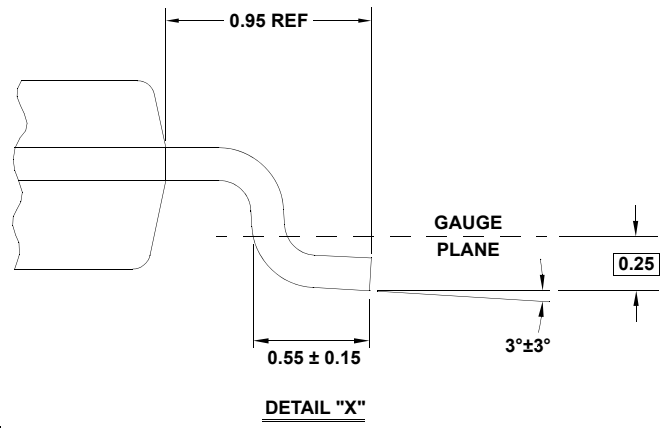
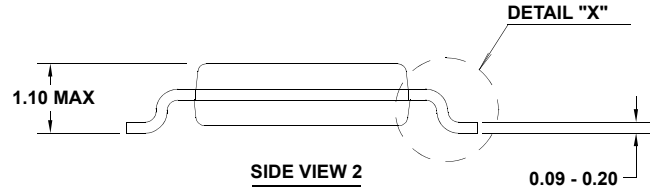
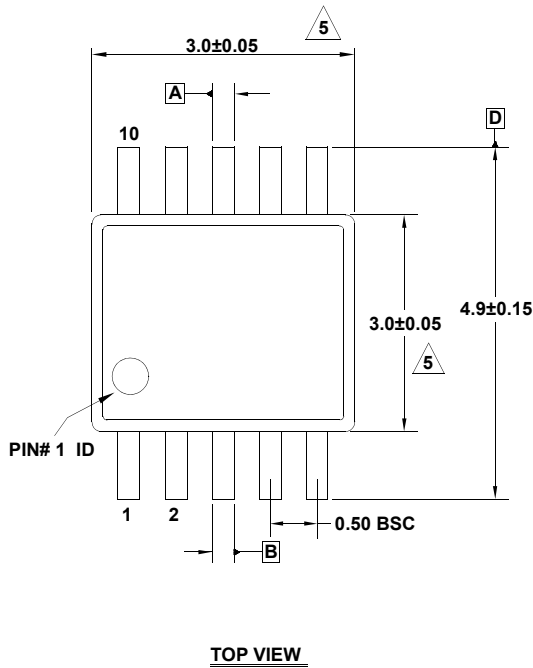

**NOTES:**

1. Dimensions are in millimeters.
2. Dimensioning and tolerancing conform to JEDEC MO-187-BA and AMSEY14.5m-1994.
3. Plastic or metal protrusions of 0.15mm max per side are not included.
4. Plastic interlead protrusions of 0.15mm max per side are not included.
5. Dimensions are measured at Datum Plane "H".
6. Dimensions in ( ) are for reference only.

For the most recent package outline drawing, see [M14.15](#).

M14.15

14 Lead Narrow Body Small Outline Plastic Package

Rev 2, 6/20

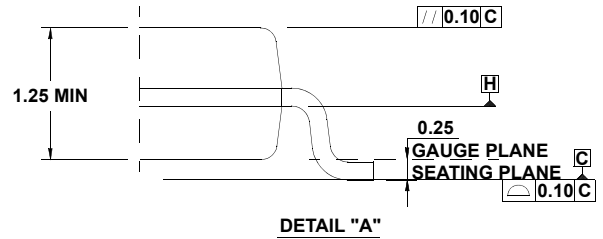
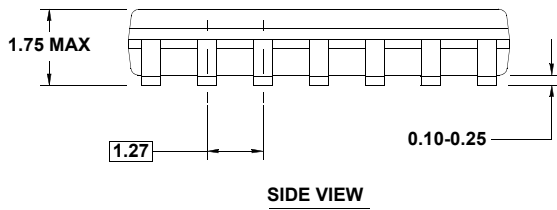
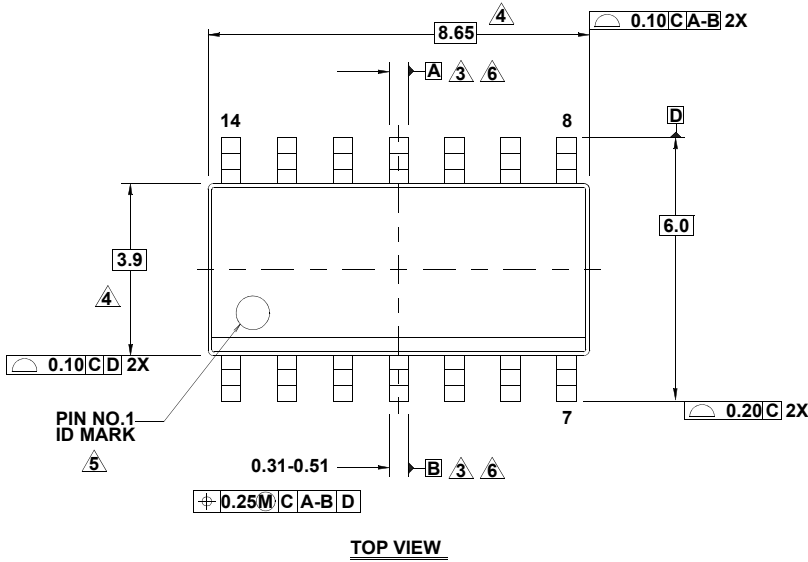

**NOTES:**

1. Dimensions are in millimeters.  
Dimensions in ( ) for Reference Only.
2. Dimensioning and tolerancing conform to AMSEY14.5m-1994.
3. Datums A and B to be determined at Datum H.
4. Dimension does not include interlead flash or protrusions.  
Interlead flash or protrusions shall not exceed 0.25mm per side.
5. The pin #1 identifier may be either a mold or mark feature.
6. Does not include dambar protrusion. Allowable dambar protrusion shall be 0.10mm total in excess of lead width at maximum condition.
7. Reference to JEDEC MS-012-AB.

## 9. Ordering Information

Part Number <sup>[1][2]</sup>	Part Marking	Package Description (RoHS Compliant)	Pkg. Dwg. #	Carrier Type (Units) <sup>[3]</sup>	Temp. Range
RAA7881502GSP#AB0	RAA788 1502GSP	14 Ld SOIC	M14.15	Tube	-40 to +85°C
RAA7881502GSP#HB0				Reel, 2.5k	
RAA7881502GSU#AB0	81502	10 Ld MSOP	M10.118	Tube	
RAA7881502GSU#HB0				Reel, 2.5k	
RAA7881522GSP#AB0	7881522	8 Ld SOIC	M8.15	Tube	
RAA7881522GSP#HB0				Reel, 2.5k	
RAA7881522GSU#AB0	81522	8 Ld MSOP	M8.118	Tube	
RAA7881522GSU#HB0				Reel, 2.5k	
RAA7881532GSP#AB0	RAA788 1532GSP	14 Ld SOIC	M14.15	Tube	
RAA7881532GSP#HB0				Reel, 2.5k	
RAA7881532GSU#AB0	81532	10 Ld MSOP	M10.118	Tube	
RAA7881532GSU#HB0				Reel, 2.5k	
RAA7881552GSP#AB0	7881552	8 Ld SOIC	M8.15	Tube	
RAA7881552GSP#HB0				Reel, 2.5k	
RAA7881552GSU#AB0	81552	8 Ld MSOP	M8.118	Tube	
RAA7881552GSU#HB0				Reel, 2.5k	
RAA7881562GSP#AB0	RAA788 1562GSP	14 Ld SOIC	M14.15	Tube	
RAA7881562GSP#HB0				Reel, 2.5k	
RAA7881562GSU#AB0	81562	10 Ld MSOP	M10.118	Tube	
RAA7881562GSU#HB0				Reel, 2.5k	
RAA7881582GSP#AB0	7881582	8 Ld SOIC	M8.15	Tube	
RAA7881582GSP#HB0				Reel, 2.5k	
RAA7881582GSU#AB0	81582	8 Ld MSOP	M8.118	Tube	
RAA7881582GSU#HB0				Reel, 2.5k	

1. These Pb-free plastic packaged products employ special Pb-free material sets, molding compounds/die attach materials, and 100% matte tin plate plus anneal (e3 termination finish, which is RoHS compliant and compatible with both SnPb and Pb-free soldering operations). Pb-free products are MSL classified at Pb-free peak reflow temperatures that meet or exceed the Pb-free requirements of IPC/JEDEC J STD-020.
2. For Moisture Sensitivity Level (MSL), see the Product Options on the [RAA788150](#), [RAA788152](#), [RAA788153](#), [RAA788155](#), [RAA788156](#), and [RAA788158](#) product pages (click the packaging icon). For more information about MSL, see [TB363](#).
3. See [TB347](#) for details about reel specifications.



Table 5. Key Differences of Device Features

Part Number	Duplex	Data Rate (Mbps)	Rise/Fall Time (ns)	Bus EFT (kV)	Bus ESD (kV)	Pin Count
RAA788150	Full	0.115	1100	±5	±10	10, 14
RAA788152	Half	0.115	1100	±5	±16	8
RAA788153	Full	1	150	±5	±10	10, 14
RAA788155	Half	1	150	±5	±16	8
RAA788156	Full	20	8	±5	±10	10, 14
RAA788158	Half	20	8	±5	±16	8

## 10. Revision History

Revision	Date	Description
1.03	Oct 2, 2023	Updated M8.15 POD to the latest revision (corrected typo).
1.02	Aug 19, 2021	Updated Figure 34. Updated Ordering Information table.
1.01	Aug 5, 2021	Updated Figures 16, 18, and 20. Updated Note 2 in the ordering information table.
1.00	Jun 15, 2021	Initial release.