

CAMBLOCK PLUS

5.08mm Inverted/Reverse Terminal Blocks

- Horizontal & vertical orientations
- Polarized moldings
- Dual low pins for extra stability
- Also available in 5mm pitch
- Also match able with CTBP9308 and 358 headers
- Molded in green UL94-V0 flame retardant PA66
- 1.5mm² (28-14AWG)
-  approved

SPECIFICATION

Rating	UL=15A/300V
Insulation resistance	500MΩ/500V
Withstand Voltage	AC2000V/1min
Contact Resistance	20mΩ (max)
Working Temperature	-40°C to 105+°C
Mouldings	UL94-V0 Flame retardant PA66
Pin/Terminal	Brass, Tin plated
Rising Clamp	Brass, nickel plated
Screw/Torque	M3 Steel, zinc plated 0.5Nm
Recommended PCB hole size	ø1.4mm

Male Vertical Connector

TYPE NO.	POLES	LENGTH
CTBP96VJ/2	2	11.76mm
CTBP96VJ/3	3	16.84mm
CTBP96VJ/4	4	21.92mm
CTBP96VJ/5	5	27mm
CTBP96VJ/6	6	32.08mm
CTBP96VJ/7	7	37.16mm
CTBP96VJ/8	8	42.24mm
CTBP96VJ/9	9	47.32mm
CTBP96VJ/10	10	52.4mm
CTBP96VJ/11	11	57.48mm
CTBP96VJ/12	12	62.56mm

CTBP96VJ

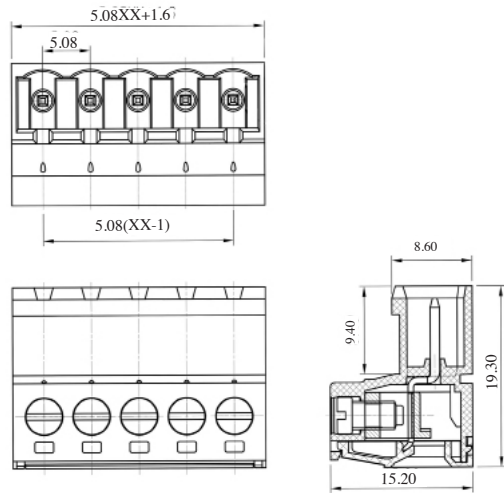

Male Vertical Connector, Flanged

TYPE NO.	POLES	LENGTH A	LENGTH B
CTBP96VJ/2FL	2	11.76mm	16.26mm
CTBP96VJ/3FL	3	16.84mm	21.34mm
CTBP96VJ/4FL	4	21.92mm	26.42mm
CTBP96VJ/5FL	5	27mm	31.5mm
CTBP96VJ/6FL	6	32.08mm	36.58mm
CTBP96VJ/7FL	7	37.16mm	41.66mm
CTBP96VJ/8FL	8	42.24mm	46.74mm
CTBP96VJ/9FL	9	47.32mm	51.82mm
CTBP96VJ/10FL	10	52.4mm	56.9mm
CTBP96VJ/11FL	11	57.48mm	61.98mm
CTBP96VJ/12FL	12	62.56mm	67.06mm

CTBP96VJ/FL

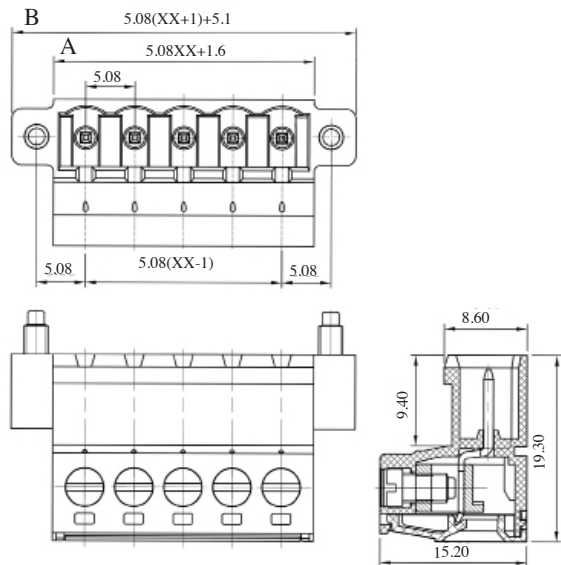

CAMBLOCK PLUS

PCB Mounting Female Vertical Connector

TYPE NO.	POLES	LENGTH	CTBP97VJ
CTBP97VJ/2	2	12.16mm	
CTBP97VJ/3	3	17.24mm	
CTBP97VJ/4	4	22.32mm	
CTBP97VJ/5	5	27.4mm	
CTBP97VJ/6	6	32.48mm	
CTBP97VJ/7	7	37.56mm	
CTBP97VJ/8	8	42.64mm	
CTBP97VJ/9	9	47.72mm	
CTBP97VJ/10	10	52.8mm	
CTBP97VJ/11	11	57.88mm	
CTBP97VJ/12	12	62.96mm	

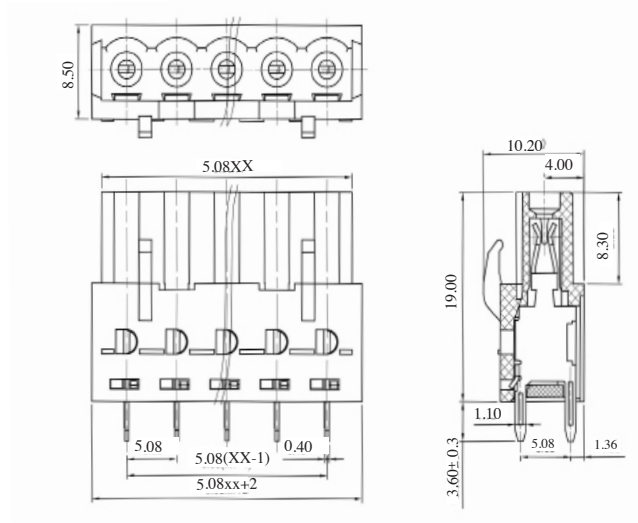

PCB Mounting Female Vertical Connector, Flanged

TYPE NO.	POLES	LENGTH A	LENGTH B	CTBP97VJ/FL
CTBP97VJ/2FL	2	12.16mm	20.32mm	
CTBP97VJ/3FL	3	17.24mm	25.4mm	
CTBP97VJ/4FL	4	22.32mm	30.48mm	
CTBP97VJ/5FL	5	27.4mm	35.56mm	
CTBP97VJ/6FL	6	32.48mm	40.64mm	
CTBP97VJ/7FL	7	37.56mm	45.72mm	
CTBP97VJ/8FL	8	42.64mm	50.8mm	
CTBP97VJ/9FL	9	47.72mm	55.88mm	
CTBP97VJ/10FL	10	52.8mm	60.96mm	
CTBP97VJ/11FL	11	57.88mm	66.04mm	
CTBP97VJ/12FL	12	62.96mm	71.12mm	

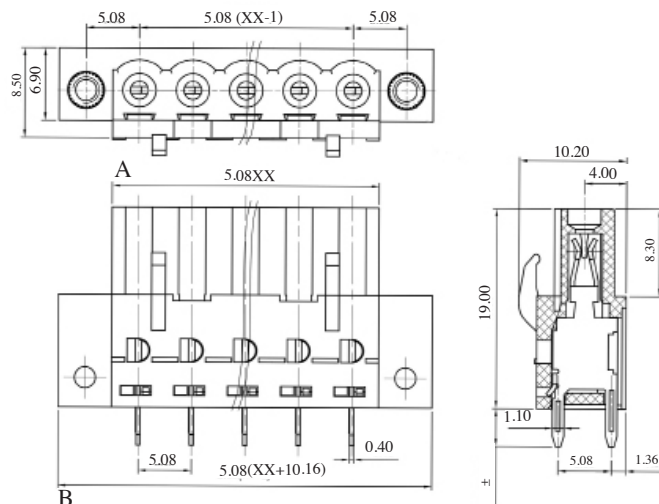

CAMBLOCK PLUS

PCB Mounting Female Horizontal

TYPE NO.	POLES	LENGTH
CTBP97HJ/2	2	12.16mm
CTBP97HJ/3	3	17.24mm
CTBP97HJ/4	4	22.32mm
CTBP97HJ/5	5	27.4mm
CTBP97HJ/6	6	32.48mm
CTBP97HJ/7	7	37.56mm
CTBP97HJ/8	8	42.64mm
CTBP97HJ/9	9	47.72mm
CTBP97HJ/10	10	52.8mm
CTBP97HJ/11	11	57.88mm
CTBP97HJ/12	12	62.96mm

CTBP97HJ

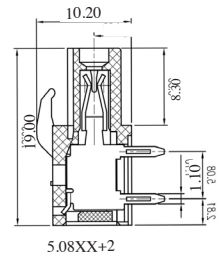
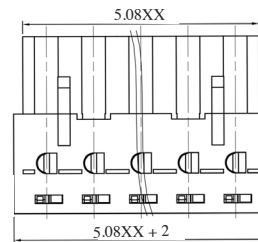
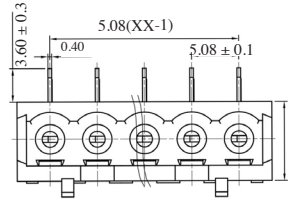

PCB Mounting Female Horizontal, Flanged

TYPE NO.	POLES	LENGTH A	LENGTH B
CTBP97HJ/2FL	2	12.16mm	20.32mm
CTBP97HJ/3FL	3	17.24mm	25.4mm
CTBP97HJ/4FL	4	22.32mm	30.48mm
CTBP97HJ/5FL	5	27.4mm	35.56mm
CTBP97HJ/6FL	6	32.48mm	40.64mm
CTBP97HJ/7FL	7	37.56mm	45.72mm
CTBP97HJ/8FL	8	42.64mm	50.8mm
CTBP97HJ/9FL	9	47.72mm	55.88mm
CTBP97HJ/10FL	10	52.8mm	60.96mm
CTBP97HJ/11FL	11	57.88mm	66.04mm
CTBP97HJ/12FL	12	62.96mm	71.12mm

CTBP97HJ/FL

