

## DESCRIPTION

The TL431 are three-terminal adjustable shunt regulators with a specified thermal stability. The output voltage may be set to any value between  $V_{ref}$  (approx. 2.5V) and 36V with two external resistors. The active output circuitry provides a very sharp turn-on characteristic making these devices an excellent replacement for zener diodes in many applications.

## FEATURE

- On-wafer  $V_{ref}$  trimming  $\pm 0.5\%$
- 95% chips after packaging have  $V_{ref}$  accuracy  $\pm 0.5\%$
- Low Dynamic output impedance 0.1 $\Omega$  (Typ)
- Adjustable output voltage
- Fast turn-on response
- Sink current capability of 0.1mA to 100mA
- Low output noise
- Industrial temperature range
- Improved temperature compensation
- Excellent temperature coefficient 25ppm/ $^{\circ}\text{C}$
- Electrostatic discharge voltage 1.6kV

## Reference News

PIN CONFIGURATION	SYMBOL	MARKING

## ABSOLUTE MAXIMUM RATINGS

(Over operating free-air temperature range, unless otherwise noted)

PARAMETER	VALUE	UNITS
Cathode voltage (Note 1)	40	V
Continuous cathode current range	-100 to 150	mA
REF (Reference) input current range	-50 $\mu\text{A}$ to 10mA	
Operating free-air temperature range	-25 to 85	$^{\circ}\text{C}$
Lead temperature (1.6mm aside from the case, 10 seconds)	260	
ESD (HBM)	2.5	kV

Note 1: The voltage values are with respect to the anode terminal unless otherwise noted.

## RECOMMENDED OPERATING CONDITIONS

PARAMETER	MIN	MAX	UNIT
Cathode voltage, $V_{KA}$	$V_{ref}$	36	V
Cathode current, $I_K$ (for regulation )	0.3	100	mA

## ELECTRICAL CHARACTERISTICS

(At 25°C free-air temperature, unless otherwise noted)

PARAMETER	SYMBOL	TEST CIRCUIT	TEST CONDITIONS	MIN	TYP	MAX	UNIT
Reference voltage accuracy at wafer testing	$dV_{ref}$	1	Wafer testing $V_{ka} = V_{ref}$	-0.5%	0%	0.5%	%
Packaged dice with $V_{ref} \pm 0.5\%$ accuracy			$V_{ka} = V_{ref}$		95%		%
REF input voltage	$V_{ref}$	1	$V_{KA} = V_{ref}$ , $I_K = 10mA$	2475	2500	2525	mV
Deviation of the REF input voltage overfull temperature range	$V_{ref(dev)}$	1	$V_{KA} = V_{ref}$ , $I_K = 10mA$ , $T_A = 0$ to $125^\circ C$		8	17	
REF input voltage-to-cathode voltage change ratio	$\Delta V_{ref}/\Delta V_{KA}$	2	$I_K = 10mA$	$\Delta V_{KA} = 10V$ to $V_{ref}$ $\Delta V_{KA} = 36V$ to $10V$	-2,7 -2	-1.0 -0.4	mV/V
REF input current	$I_{ref}$	2	$I_K = 10mA$ , $R1 = 10k\Omega$ , $R2 = \infty$		0.5	1.2	$\mu A$
Deviation of the REF input current overfull temperature range	$I_{ref(dev)}$	2	$I_K = 10mA$ , $R1 = 10k\Omega$ , $R2 = \infty$ , $T_A =$ full range		0.4	1.2	
Minimum cathode current for regulation	$I_{min}$	1	$V_{KA} = V_{ref}$		0.08	0.5	mA
Off-state cathode current	$I_{off}$	3	$V_{KA} = 36V$ , $V_{ref} = 0$		0.01	0.9	$\mu A$
Dynamic impedance	$I_{Z_{KA}}$	1	$V_{KA} = V_{ref}$ , $I_K = 0.2mA$ to $100mA$ , $f < 1kHz$		0.1	0.5	$\Omega$

## PARAMETER MEASUREMENT INFORMATION

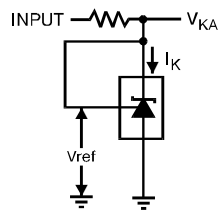

FIGURE 1. TEST CIRCUIT FOR  $V_{KA} = V_{ref}$

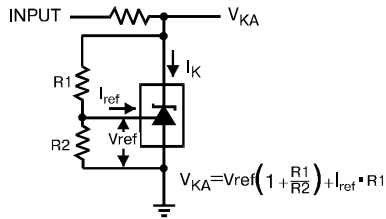

FIGURE 2. TEST CIRCUIT FOR  $V_{KA} > V_{ref}$

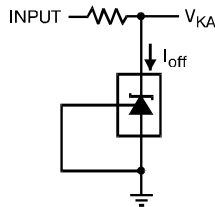

FIGURE 3. TEST CIRCUIT FOR  $I_{off}$

## TYPICAL CHARACTERISTICS

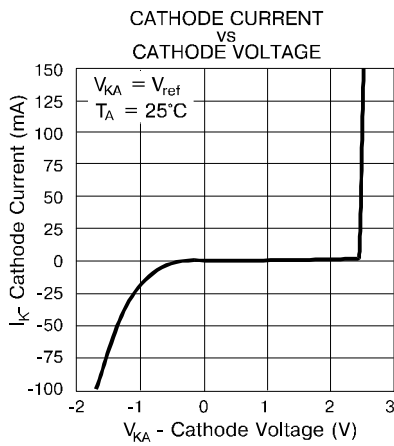

FIGURE 1

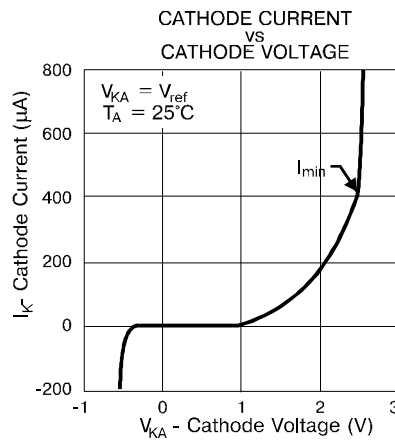

FIGURE 2

## TYPICAL APPLICATIONS

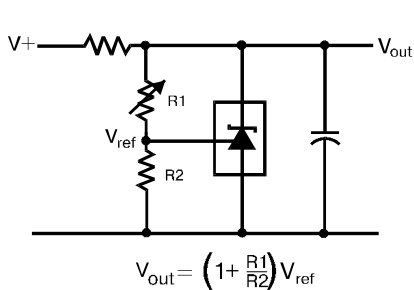

FIGURE 1. SHUNT REGULATOR

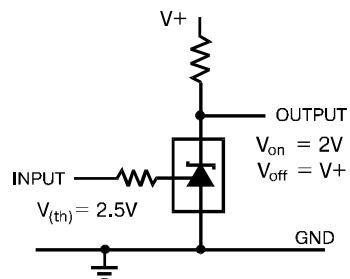
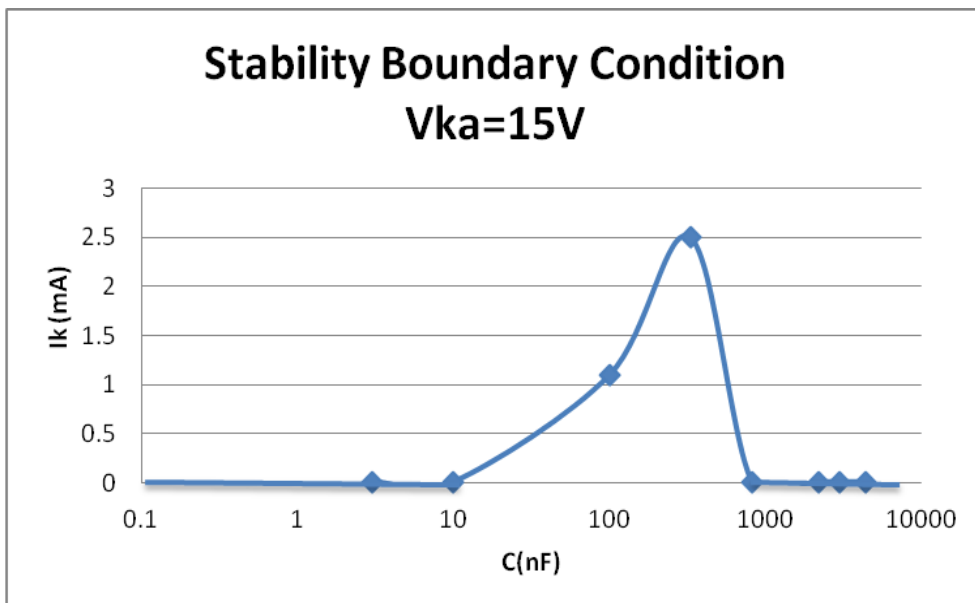
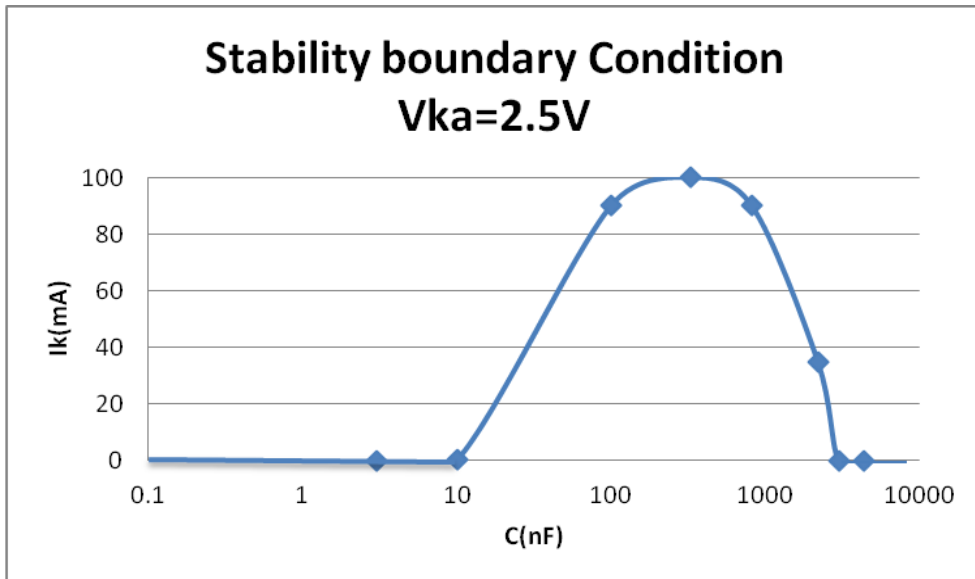
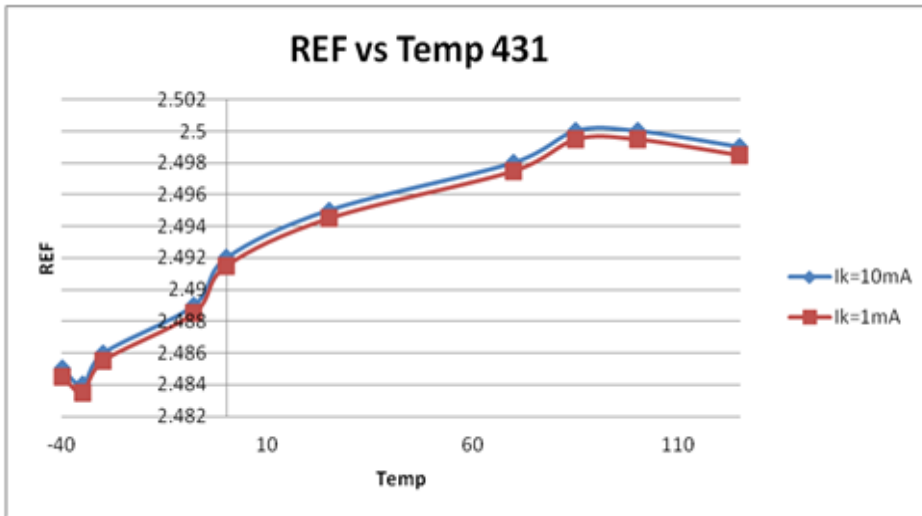
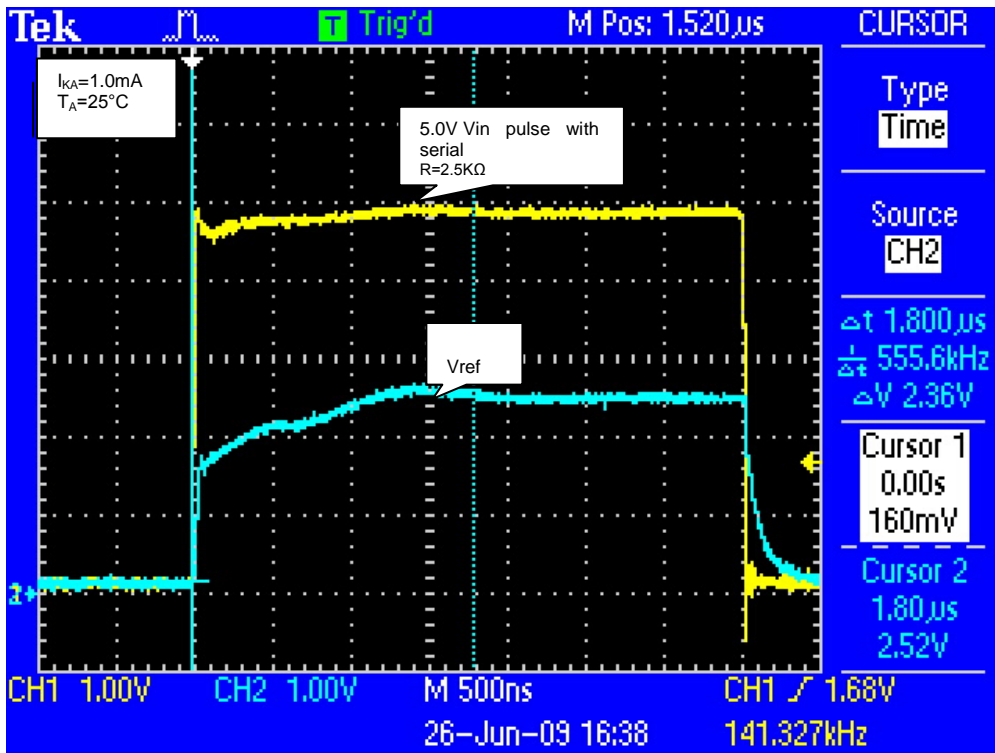

FIGURE 2. SINGLE-SUPPLY COMPARATOR WITH TEMPERATURE-COMPENSATED THRESHOLD

## TYPICAL PERFORMANCE CHARACTERISTICS



## PULSE RESPONSE



Pulse response:  $T_{on} = 1.8\mu\text{s}$

## PACKAGE MECHANICAL DATA

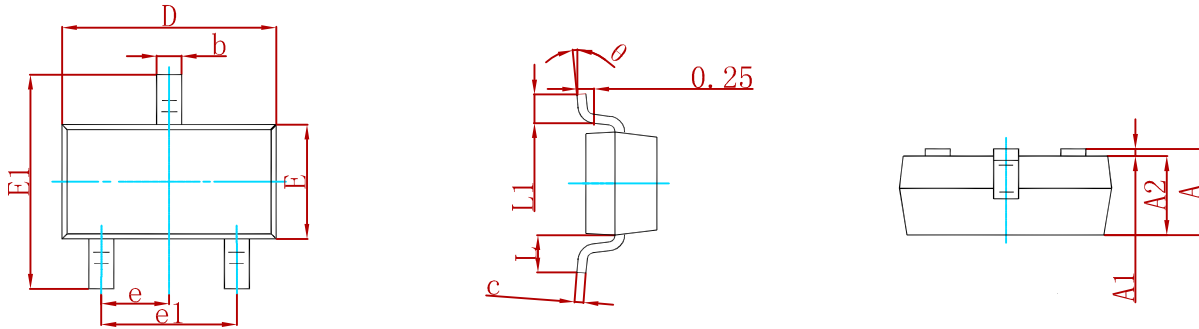

Symbol	Dimensions In Millimeters		Dimensions In Inches	
	Min	Max	Min	Max
A	0.900	1.150	0.035	0.045
A1	0.000	0.100	0.000	0.004
A2	0.900	1.050	0.035	0.041
b	0.300	0.500	0.012	0.020
c	0.080	0.150	0.003	0.006
D	2.800	3.000	0.110	0.118
E	1.200	1.400	0.047	0.055
E1	2.250	2.550	0.089	0.100
e	0.950 TYP		0.037 TYP	
e1	1.800	2.000	0.071	0.079
L	0.550 REF		0.022 REF	
L1	0.300	0.500	0.012	0.020
θ	0°	8°	0°	8°

## Suggested Pad Layout

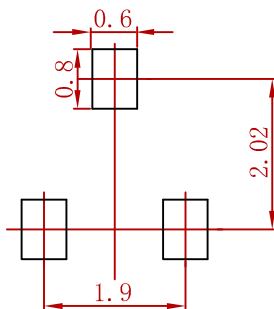

**Note:**

1. Controlling dimension: in millimeters.
2. General tolerance:  $\pm 0.05\text{mm}$ .
3. The pad layout is for reference purposes only.

## REEL SPECIFICATION

P/N	PKG	QTY
TL431	SOT-23	3000