

SPECIFICATION FOR APPROVAL

REF. :

PROD. NAME	Semi-shielded SMD Power Inductor	ABC'S DWG NO.		ESN3015□□□□S□-□□□	
		REV.	20181009-B	PAGE	1

I . Configuration and dimensions :

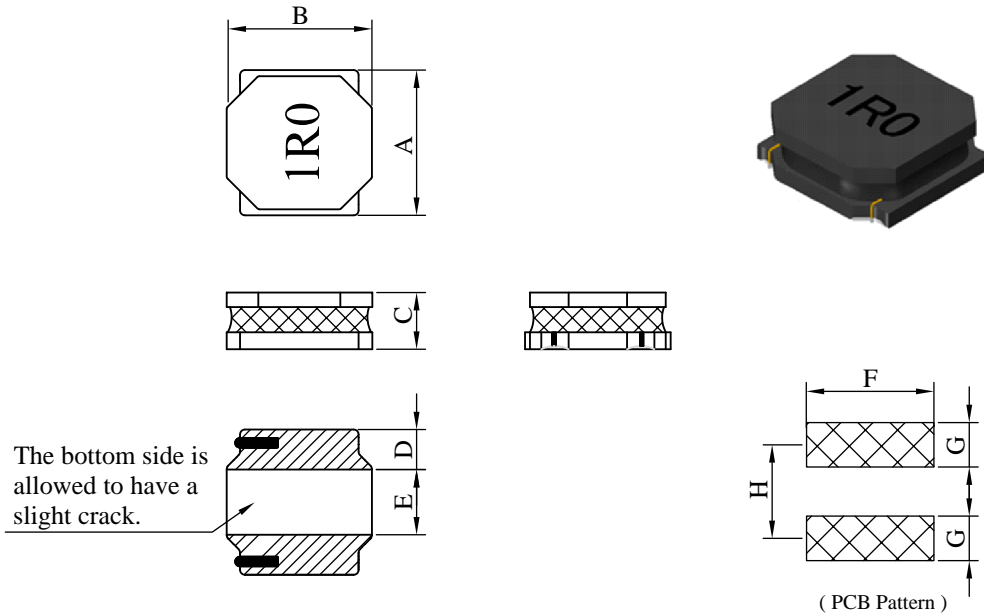

Unit : m/m

A	B	C	D	E	F	G	H
3.00 ±0.2	3.00 ±0.2	1.55 max.	0.90 ref.	1.20 ref.	2.90 ref.	1.20 ref.	2.10 ref.

II . Description :

- a . Ferrite drum core construction.
- b . Enamelled copper wire : H class
- c . Product weight : 0.04 g (ref.)
- d . Moisture sensitivity Level 1
- e . Products comply with RoHS' requirements
- f . Halogen free

III . General specification :

- a . Storage temp. : -40°C ----+125°C
- b . Operating temp. : -40°C ----+125°C
(Temp. rise included)
- c . Resistance to solder heat : 260°C .10 secs.

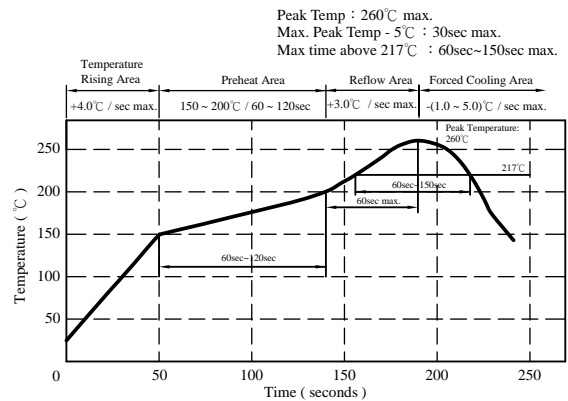

AR-001C

SPECIFICATION FOR APPROVAL

REF. :

PROD. NAME	Semi-shielded SMD Power Inductor	ABC'S DWG NO.	ESN3015□□□□S□-□□□		
		REV.	20181009-B	PAGE	2

IV . Electrical characteristics :

DWG. No.	Inductance (uH)	Test Freq. (Hz)	RDC (mΩ) max.	Isat (A) max.	Irms (A) max.
ESN30151R0YS□-□□□	1.00 ±30%	100k/0.25V	48.0	2.32	2.80
ESN30151R5MS□-□□□	1.50 ±20%	100k/0.25V	65.0	2.10	2.70
ESN30152R2MS□-□□□	2.20 ±20%	100k/0.25V	78.0	1.60	2.20
ESN30153R3MS□-□□□	3.30 ±20%	100k/0.25V	104.0	1.30	1.80
ESN30154R7MS□-□□□	4.70 ±20%	100k/0.25V	160.0	1.10	1.50
ESN30156R8MS□-□□□	6.80 ±20%	100k/0.25V	234.0	0.85	1.25
ESN3015100MS□-□□□	10.00 ±20%	100k/0.25V	338.0	0.70	1.10
ESN3015150MS□-□□□	15.00 ±20%	100k/0.25V	438.0	0.60	1.00
ESN3015220MS□-□□□	22.00 ±20%	100k/0.25V	598.0	0.52	0.85
ESN3015330MS□-□□□	33.00 ±20%	100k/0.25V	1066.0	0.44	0.70
ESN3015470MS□-□□□	47.00 ±20%	100k/0.25V	1600.0	0.35	0.40
ESN3015680MS□-□□□	68.00 ±20%	100k/0.25V	2340.0	0.28	0.35

- 1). Electrical specifications at 25°C
- 2). Isat base on $\Delta L/L0A=30\%$ max. (Approximately transient current)
- 3). Irms base on temp. rise 40°C max.

AR-001C

SPECIFICATION FOR APPROVAL

REF. :

PROD. NAME	Semi-shielded SMD Power Inductor	ABC'S DWG NO.	ESN3015□□□□S□-□□□		
		REV.	20181009-B	PAGE	3

V . Curve :

ESN30151R0YS□

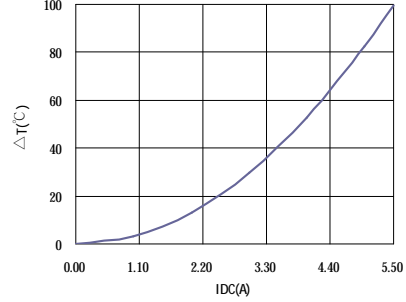
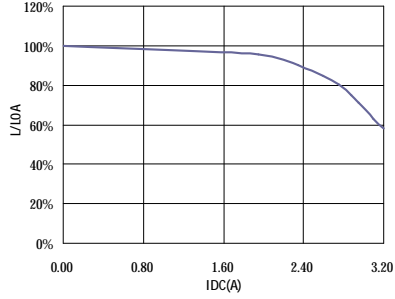

ESN30156R8MS□

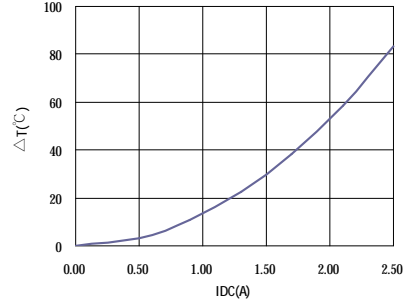
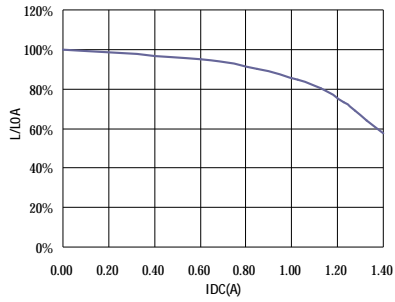

ESN3015100MS□

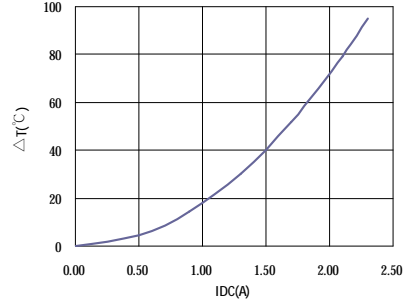
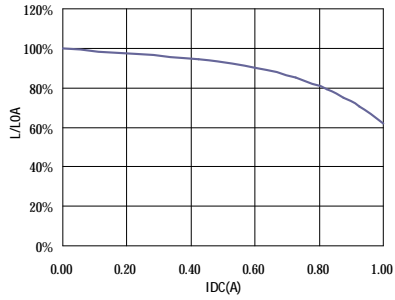

ESN3015680MS□

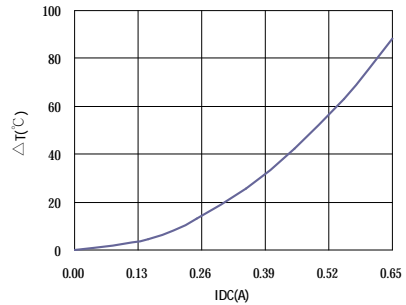
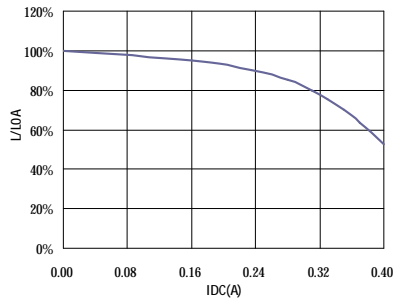

AR-001C

SPECIFICATION FOR APPROVAL

REF. :

PROD. NAME	Semi-shielded SMD Power Inductor	ABC'S DWG NO.		ESN3015□□□□S□-□□□	
		REV.	20181009-B	PAGE	4

VI . Packaging information :

(1) Configuration

※Carrier tape width : D

(2) Dimensions Unit:m/m

Style	A	B	C	D	G	N	T
07-08	178	21±0.8	13	8	10 ⁺⁰	50 ⁻⁰	12.5

(3) Q'TY & G.W. Per package

Code	Inner : Reel			Outer : Carton		
	Q'TY (pcs)	G.W. (g)	Style	Q'TY (pcs)	G.W. (Kg)	Size (cm)
B	2,000	185	07-08	48,000	10.7	41 x 41 x 18

AR-001C

SPECIFICATION FOR APPROVAL

REF. :

PROD. NAME	Semi-shielded SMD Power Inductor	ABC'S DWG NO.	ESN3015□□□□S□-□□□		
		REV.	20181009-B	PAGE	6

VIII . Reliability test :

Item	Reference documents	Test Condition	Test Specification
1.High Temperature Exposure	MIL-STD-202 Method 108	1.Temperature: 125±2°C 2.Time:96±2 hours.	1.No mechanical or electrical damage. 2.Inductance shall not change more than ±20%.
2.Temperature Cycling	JESD22-A 104	1.Temperature: -40°C ~ +125°C 2.Number of cycle:100 cycle 3.Dwell time:30 minutes	1.No mechanical or electrical damage. 2.Inductance shall not change more than ±20%.
3.Biased Humidity Test	MIL-STD-202 Method 103	1.Temperature : 85±2 °C 2.Humidity: 85% RH. 3.Time:96±2 Hours	1.No mechanical or electrical damage. 2.Inductance shall not change more than ±20%.
4.Operational Life	JESD22-A 108	1.Temperature: 125°C (Temp. rise included) 2.Time:96±2 hours. 3.Rated current :	1.No mechanical or electrical damage. 2.Inductance shall not change more than ±20%.
5.External Visual	JESD22-B 101 & MIL-STD-883 Method 2009	Inspect product constructions, marking and workmanship.	1.No pollution on the surface of products. 2.Clear marking. 3.No crack. (marking side)
6.Physical Dimensions	JESD22-B 100	Verify physical dimensions to the applicable product detail specification.	Per product specification standard
7.Resistance to solvents	MIL-STD-202 Method 215	Immerse into solvent for 3±0.5 minutes & brush 10 times for 3 cycles.	1.No body change in apperance. 2.No marking blurred. 3.Inductance shall not change more than ±20%.
8.Vibration Test	MIL-STD-202 Method 204	1.Frequency and Amplitued : 10-2000-10 Hz, 1.5 mm. 2.Direction:X, Y, Z 3.Test duration:2 hours for each direction, 6 hours in total.	1.No mechanical or electrical damage. 2.Inductance shall not change more than ±20%.
9.Resistance To Soldering Heat Test	MIL-STD-202 Method 210 & J-STD020D.1	1.Highest temperature : 260±5°C. 2.Time (temp. ≥ 217°C) : 60~150 Second. 3.IR reflow times : 3 times.	1.No mechanical or electrical damage. 2.Inductance shall not change more than ±20%.
10.Saturation Current	JIS C 6436 & User SPEC.	1.Applied rated current for 5 second. 2.Saturation current :	Inductance shall not drop more than 30% max.
11.Over load	JIS C 6436 & User SPEC.	1.Applied one and half rated current for a period of 5 minutes. 2.Rated current :	No electrical or mechanical damage
12.Temperature Rise Current	JIS C 6436 & User SPEC.	1.Applied rated current for 10 minutes. 2.Temperature measure by digital surface thermometer. 3.Irms current :	Surface temperature rise is less than 40°C max.
13.Solderability Test	J-STD-002 & JESD22-B 102	1.Baking in pre-testing : 150±5°C / 16Hours±30 min. 2.Peak temperature : 240±5°C 3.Time (temp. ≥ 217°C) : 60~150 second. 4.IR reflow times : 1 times.	More than 95% soldering coverage min on terminations.
14.Electrical Characteriazation	MIL-STD-202 Method 304 & User SPEC.	1.Operating temperature : -40°C~125°C 2.Room temperature : 25°C.	1.No mechanical or electrical damage. 2.Inductance shall not change more than ±20%.
15.Drop	CNS-C6354 & GB/T 2423.8	1.Products shall be mounted on SPEC. PCB and dropped down from a height of 1m 2.Drop total time : 6 time (Every side of sample drop 2 time)	1. Adhesion on PCB shall be enough. 2. Product appearance shall not break. 3. No electrical damage.
16.Terminal Strength Test	IEC 60068-2-21	1.Apply push force to samples mounted on PCB. 2.Force of 1.8 kg for 60±1 seconds.	After test, inductors shall be no mechanical damage.

AR-001C

SPECIFICATION FOR APPROVAL

REF. :

PROD. NAME	Semi-shielded SMD Power Inductor	ABC'S DWG NO.	ESN3015□□□□S□-□□□		
		REV.	20181009-B	PAGE	7
IX . Change history :					
DATE/REV.	DISCRIPTION	DRAWN	CHECKED	APPROVED	
20180209-A	Released	Lijuan Y	Alan	Roger	
20181009-B	Change the Reliability test external visual item Product test specification ,No crack add the marking side	Lijuan Y	Cyrus	Roger	

AR-001C