

芯伯乐®
X I N B O L E

Product Specification

AON7403

P-Channel Enhancement Mode MOSFET

WEB | www.xinboleic.com



Descriptions

The AON7403 uses advanced trench technology and design to provide excellent $R_{DS(ON)}$ with low gate charge. This device is well suited for high current load applications.

Features

- $V_{DS} = -30V, I_D = -35A$
- $R_{DS(ON)} < 15m\Omega @ V_{GS} = -10V$
- $R_{DS(ON)} < 26m\Omega @ V_{GS} = -4.5V$

Applications

- High side switch for full bridge converter
- DC/DC converter for LCD display

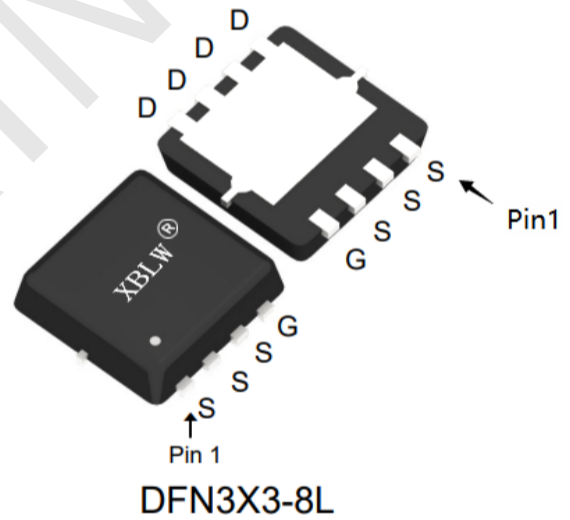
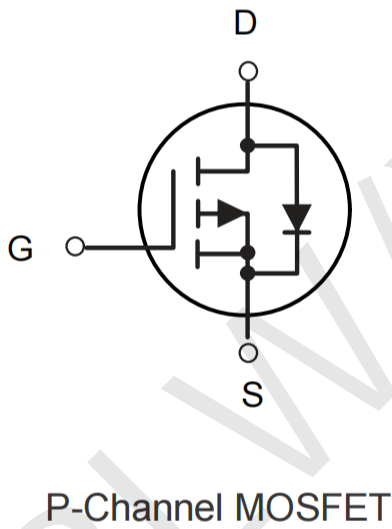

Ordering Information

Product Model	Package Type	Marking	Packing	Packing Qty
AON7403	DFN3x3-8L	AON7403	Tape	5000Pcs/Reel

Absolute Maximum Ratings ($T_J=25\text{ °C}$ unless otherwise noted)

Symbol	Parameter	Rating	Units
V_{DS}	Drain-Source Voltage	-30	V
V_{GS}	Gate-Source Voltage	± 20	V
$I_D@T_A=25\text{ °C}$	Drain Current ³ , V_{GS} @ 10V	-35	A
$I_D@T_A=70\text{ °C}$	Drain Current ³ , V_{GS} @ 10V	-25	A
I_{DM}	Pulsed Drain Current ¹	-120	A
$P_D@T_A=25\text{ °C}$	Total Power Dissipation	15	W
TSTG	Storage Temperature Range	-55 to 150	°C
T_J	Operating Junction Temperature Range	-55 to 150	°C
Rthj-c	Maximum Thermal Resistance, Junction-case	6	°C/W
Rthj-a	Maximum Thermal Resistance, Junction-ambient ³	66	°C/W

Electrical Characteristics (T_J=25°C unless otherwise specified)

Symbol	Parameter	Test Condition	Min.	Typ.	Max.	Units
V _{(BR)DSS}	Drain-Source Breakdown Voltage	V _{GS} =0V, I _D = -250μA	-30	-	-	V
I _{DSS}	Zero Gate Voltage Drain Current	V _{DS} = -30V, V _{GS} =0V,	-	-	-1	μA
I _{GSS}	Gate to Body Leakage Current	V _{DS} =0V, V _{GS} = ±20V	-	-	±100	nA
V _{GS(th)}	Gate Threshold Voltage	V _{DS} =V _{GS} , I _D = -250μA	-1.0	-1.6	-2.5	V
R _{DS(on)}	Static Drain-Source on-Resistance <small>Note3</small>	V _{GS} = -10V, I _D = -10A	-	12	15	mΩ
		V _{GS} = -4.5V, I _D = -5A	-	18	26	
C _{iss}	Input Capacitance	V _{DS} = -15V, V _{GS} =0V, f=1.0MHz	-	1330	-	pF
C _{oss}	Output Capacitance		-	183	-	pF
C _{rss}	Reverse Transfer Capacitance		-	156	-	pF
Q _g	Total Gate Charge	V _{DS} = -15V, I _D = -5A, V _{GS} = -10V	-	22	-	nC
Q _{gs}	Gate-Source Charge		-	1.0	-	nC
Q _{gd}	Gate-Drain("Miller") Charge		-	1.8	-	nC
t _{d(on)}	Turn-on Delay Time	V _{DD} = -15V, I _D = - 10A, V _{GS} =-10V, R _{GEN} =2.5Ω	-	9	-	ns
t _r	Turn-on Rise Time		-	13	-	ns
t _{d(off)}	Turn-off Delay Time		-	48	-	ns
t _f	Turn-off Fall Time		-	20	-	ns
I _S	Maximum Continuous Drain to Source Diode Forward Current		-	-	-35	A
I _{SM}	Maximum Pulsed Drain to Source Diode Forward Current		-	-	-90	A
V _{SD}	Drain to Source Diode Forward Voltage	V _{GS} =0V, I _S = -15A	-	-0.8	-1.2	V
t _{rr}	Reverse Recovery Time	T _J =25°C,	-	64	-	ns
Q _{rr}	Reverse Recovery Charge	V _{DD} = -24V, I _F =-2.8A, dI/dt=-100A/μs	-	25	-	nC

Notes: 1. Repetitive Rating: Pulse Width Limited by Maximum Junction Temperature.

2. EAS condition: T_J=25°C, V_{GS}=10V, V_G=10V, R_G=25Ω, L=0.5mH, I_{AS}=-12.7A.

3. Pulse Test: Pulse Width≤300μs, Duty Cycle≤0.5%.

Typical Characteristics

Fig 1. Output Characteristics

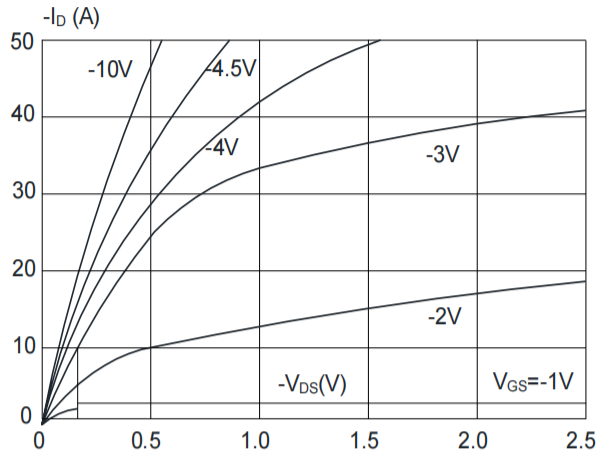

Fig 2. Typical Transfer Characteristics

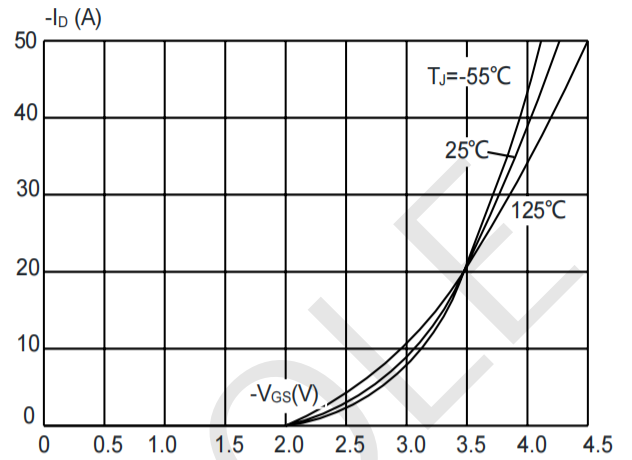

Fig 3. On-resistance vs. Drain Current

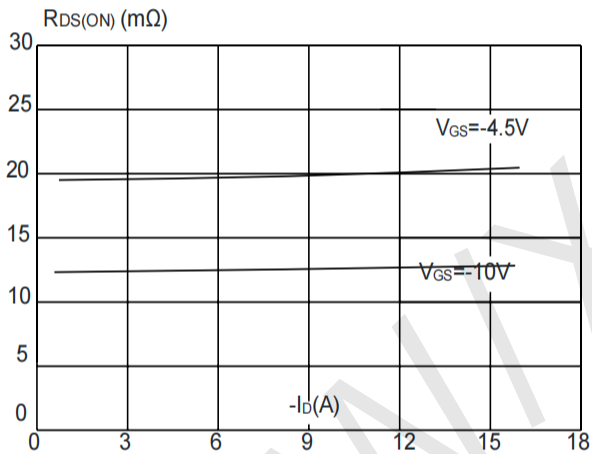

Fig 4. Body Diode Characteristics

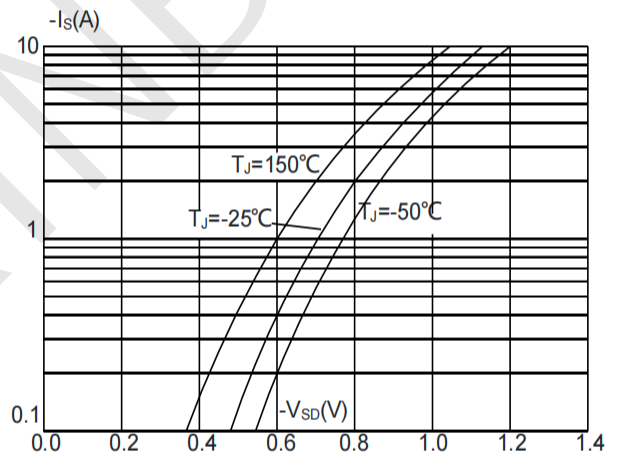

Fig 5. Gate Charge Characteristics

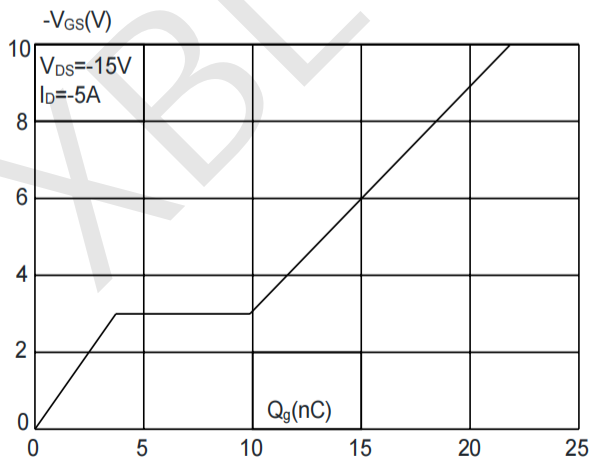

Fig 6. Capacitance Characteristics

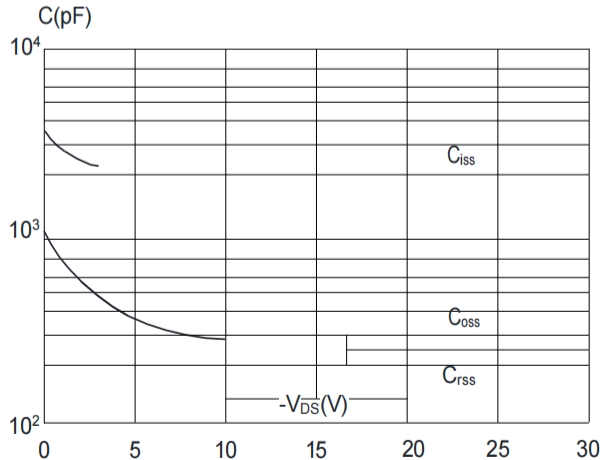

Fig 7. Normalized Breakdown Voltage vs. Junction Temperature

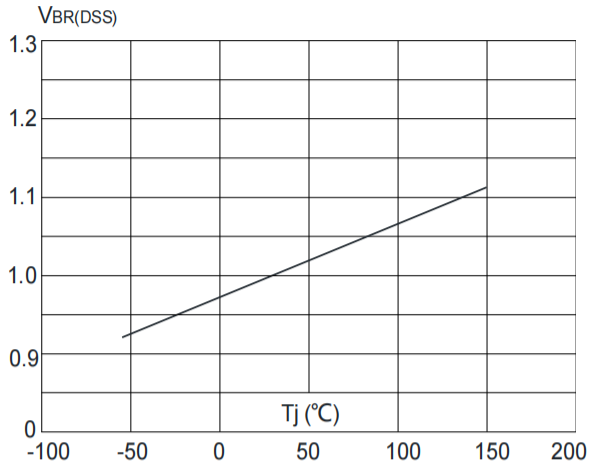

Fig 8. Normalized on Resistance vs. Junction Temperature

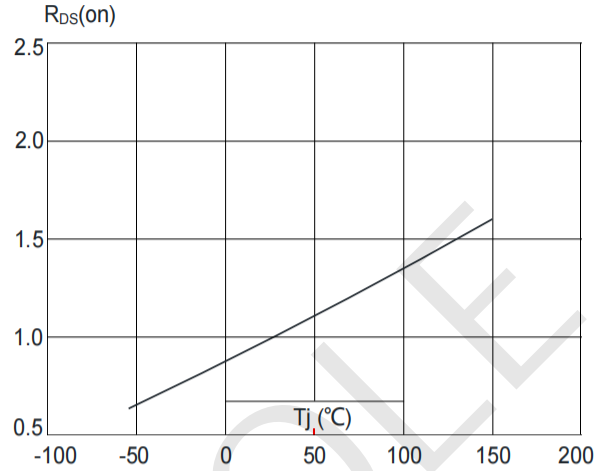

Fig 9. Maximum Safe Operating Area

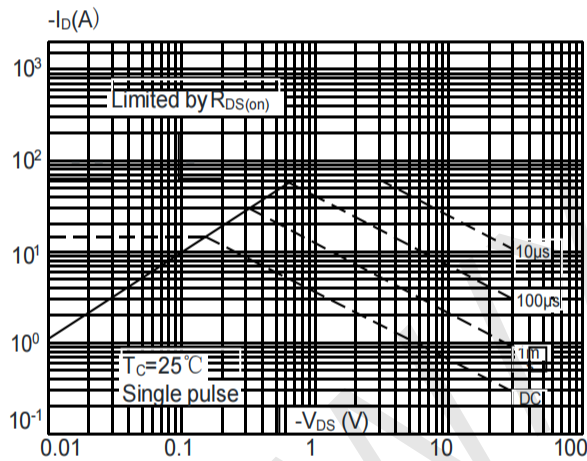

Fig 10. Maximum Continuous Drain Current vs. Case Temperature

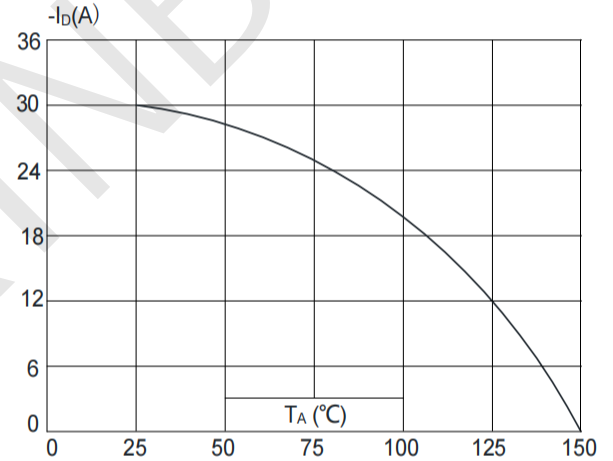
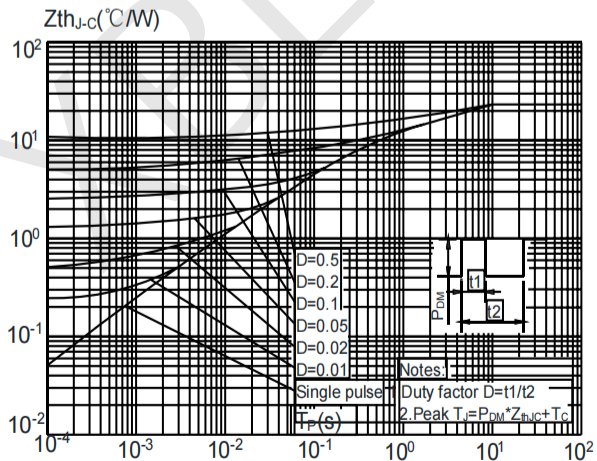
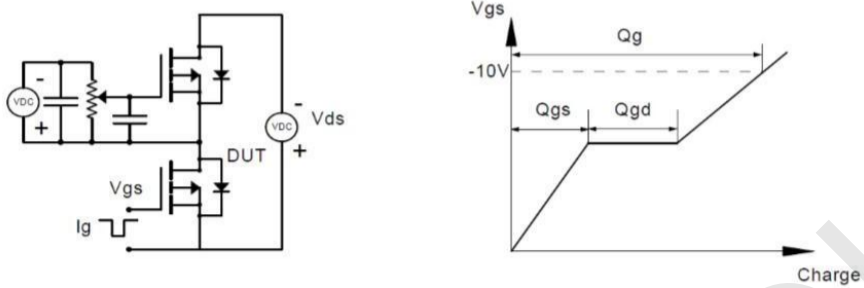

Fig 11. Maximum Effective Transient Thermal Impedance, Junction-to-Case



Test Circuit

Gate Charge Test Circuit & Waveform



Resistive Switching Test Circuit & Waveforms

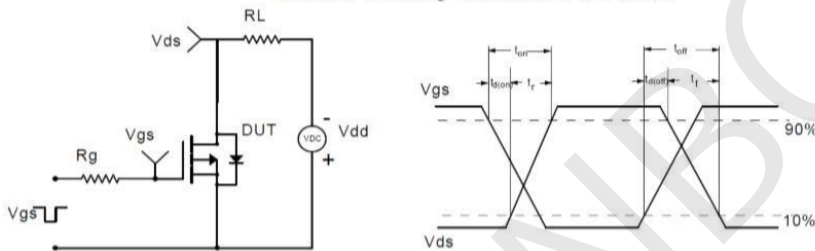

Unclamped Inductive Switching (UIS) Test Circuit & Waveforms

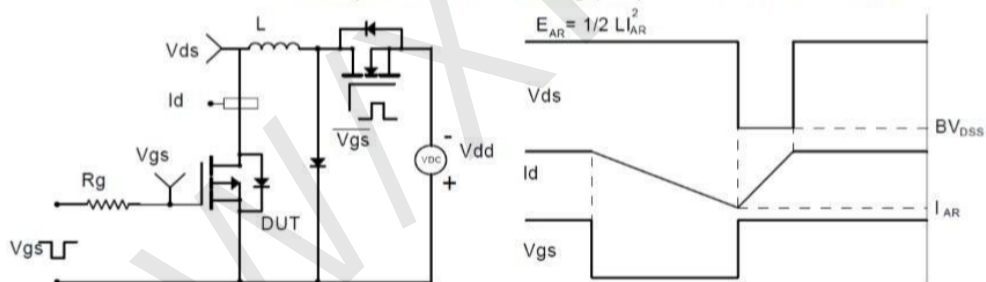

Diode Recovery Test Circuit & Waveforms

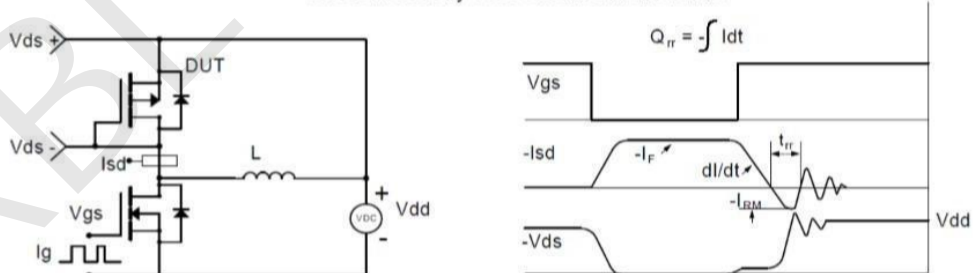

Package Information

DFN3X3-8L

Symbol	Dimensions In Millimeters		
	Min.	Nom.	Max.
A	0.70	0.75	0.80
b	0.25	0.30	0.35
c	0.10	0.15	0.25
D	3.25	3.35	3.45
D1	3.00	3.10	3.20
D2	1.48	1.58	1.68
D3	-	0.13	-
E	3.20	3.30	3.40
E1	3.00	3.15	3.20
E2	2.39	2.49	2.59
e	0.65BSC		
H	0.30	0.39	0.50
L	0.30	0.40	0.50
L1	-	0.13	-
M	*	*	0.15
θ		10°	12°

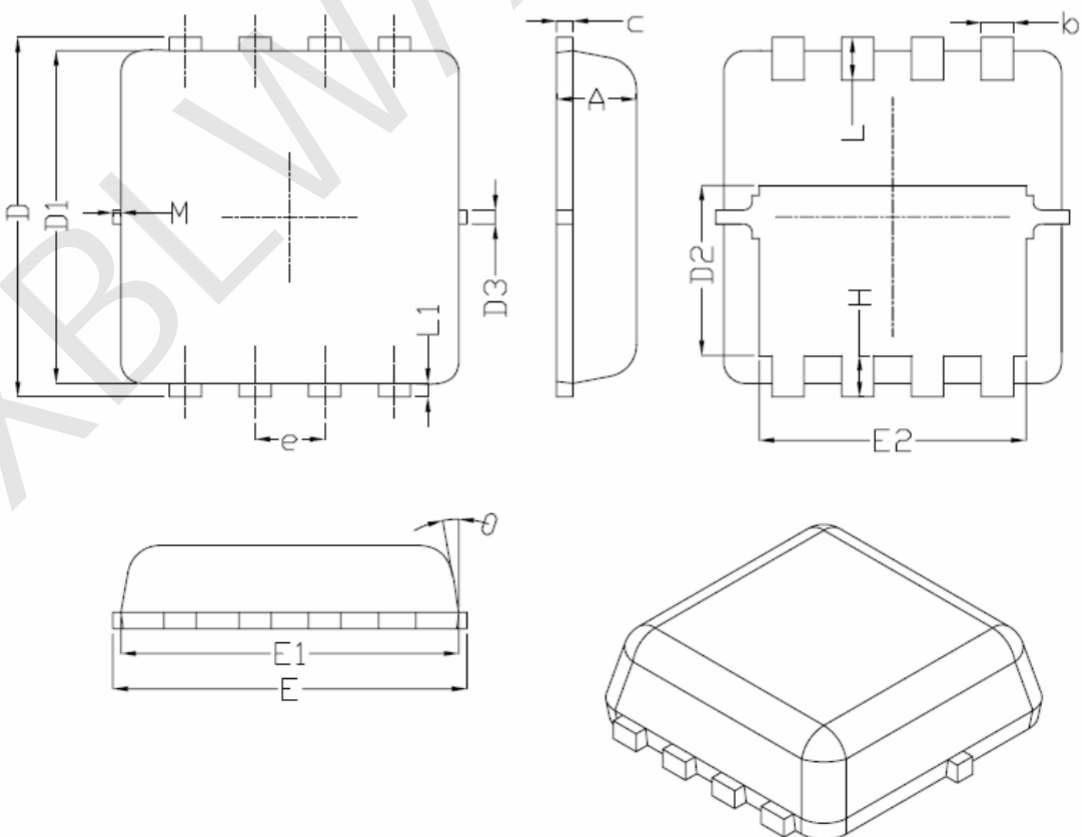

Statement:

- XBLW reserves the right to modify the product manual without prior notice! Before placing an order, customers need to confirm whether the obtained information is the latest version and verify the completeness of the relevant information.
- Any semiconductor product may malfunction under specified conditions. When using XBLW products for system design and overall manufacturing, the buyer is responsible for complying with safety standards and taking appropriate safety measures to avoid risks that may cause personal injury or property damage.
- XBLW products have not been licensed for life support, military, and aerospace applications, and therefore XBLW is not responsible for any consequences arising from the use of this product in these areas.
- If any or all XBLW products (including technical data, services) described or contained in this document are subject to any applicable local export control laws and regulations, they may not be exported without an export license from the relevant authorities in accordance with such laws.
- The specifications of any and all XBLW products described or contained in this document specify the performance, characteristics, and functionality of said products in their standalone state, but do not guarantee the performance, characteristics, and functionality of said products installed in Customer's products or equipment. In order to verify symptoms and conditions that cannot be evaluated in a standalone device, the Customer should ultimately evaluate and test the device installed in the Customer's product device.
- XBLW documentation is only allowed to be copied without any alteration of the content and with the relevant authorization. XBLW assumes no responsibility or liability for altered documents.
- XBLW is committed to becoming the preferred semiconductor brand for customers, and XBLW will strive to provide customers with better performance and better quality products.