

För icke direkt toleranssatta mått gäller toleransklass
 General tolerances if not otherwise stated

NOM DIM MM		TOL CLASS		
From	To	A	B	C
(1)	6	±0.05	±0.1	±0.2
(6)	30	±0.1	±0.2	±0.5
(30)	100	±0.15	±0.3	±0.8
(100)	300	±0.2	±0.5	±1.2
(300)	1000	±0.3	±0.8	±2

Hål / Holes H13

Skarpa kanter brutna där ej annat anges.
 No sharp edges unless otherwise specified.

Övriga generella toleranser enligt ritning 4100-4644.
 Additional general tolerances in accordance with drawing 4100-4644.

LASERMÄRKT ENLIGT RITNING : 4101-0261 F
 LASERMARKED ACCORDING TO DRAWING : 4101-0261 F

Rev	Change order	Change: A = Added W = Was D = Deleted	Date	Sign
3	1014994000	4101-0272 ÄNDRAD/CHANGED	021017	SE
4	1016252000	4101-0261F ÄNDRAD/CHANGED	030508	SE

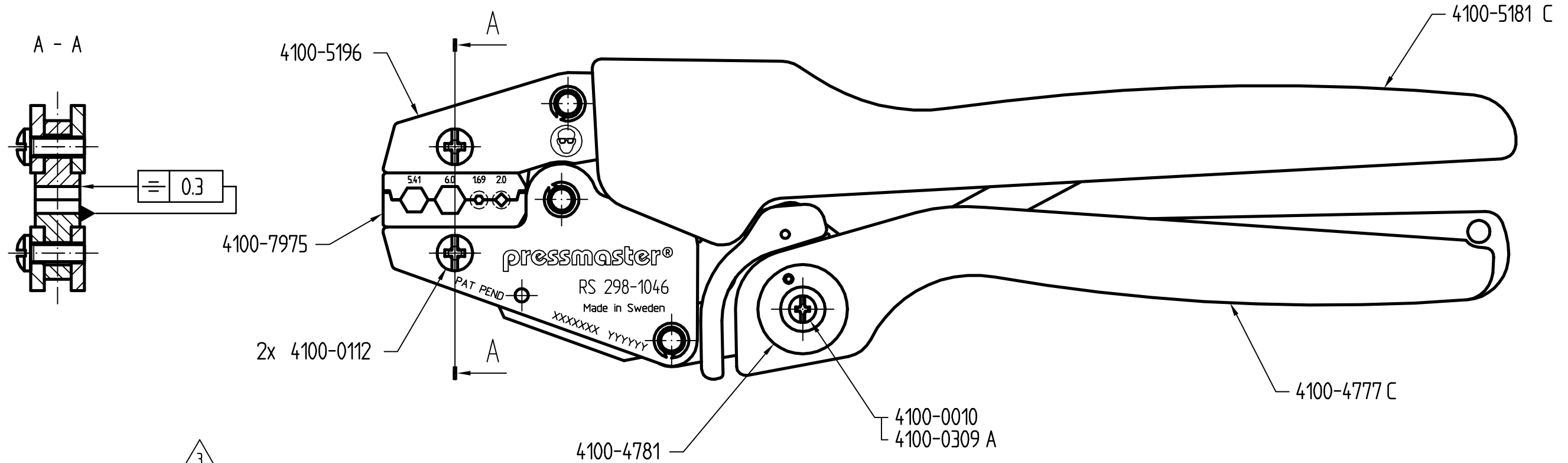
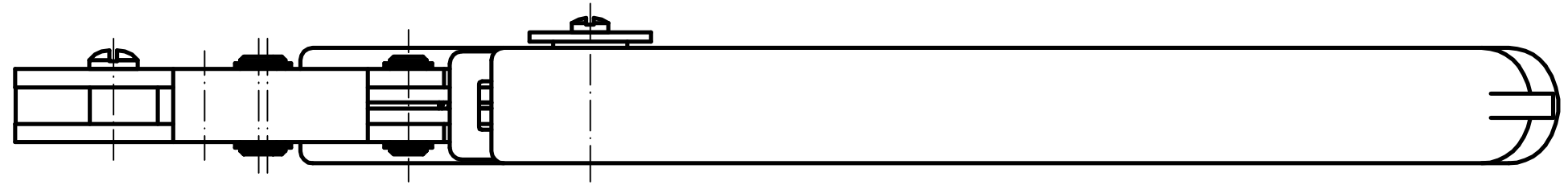

3
 4101-0272

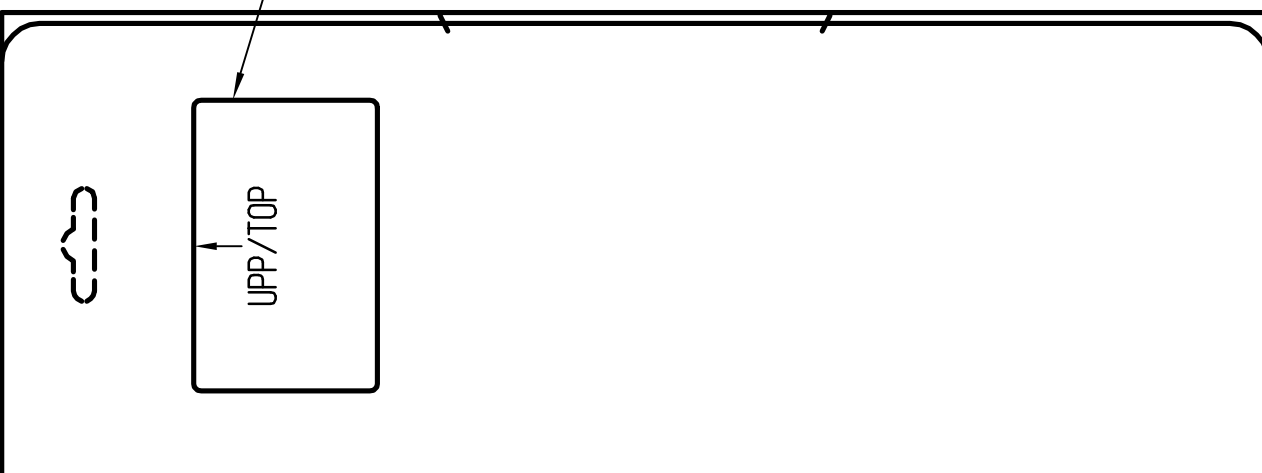

FÖRSPÄNNING / PRELOAD: 190 ± 40 N

Tolkmått / Gauge dimensions (mm)		
URTAG NEST	Gåttolk GO	Stopptolk NO GO
5.41	Ø5.36	Ø5.46
6.0	Ø5.95	Ø6.05
1.69	Ø1.66	Ø1.72
2.0	Ø1.97	Ø2.03

4100-5200
 4100-4787

Material		Behandling/Treatment			Status	
Konstr/Design	Ritad/Drawn	Datum/Date	Skala/Scale	Kontr/Checked	Godk/Approved	Ämne/Blank
OS	LJ	980420	1:1			Prel.utc.
pressmaster®					Vikt/Weight, gram	
Krimptång 298-1046					Art grp 012	
CRIMPING TOOL					Ritn nr/Drawing no	
ISO 9001 REG NR FM13687					43002436	
					REV 004	

Denna ritning är Pressmaster ABs egendom. Skyddad av gällande lag.
 This drawing is the property of Pressmaster AB. Protected in accordance with prevailing law.